

# Positioniereinheiten

## *Positioning units*

---



**... mit Zahnriemenantrieb**  
**... with toothed belt drive**

---

Zahnriemenantrieb / <i>Toothed belt drive</i> _____	40
Die Einstiegsklasse / <i>The basic class</i> _____	42
Die Premiumklasse / <i>The premium class</i> _____	54
Die Auslegerachsen / <i>The cantilever axis</i> _____	64
Motoranbauvarianten / <i>Motor attachment variants</i> _____	72

# Zahnriemenantrieb

## Toothed belt drive

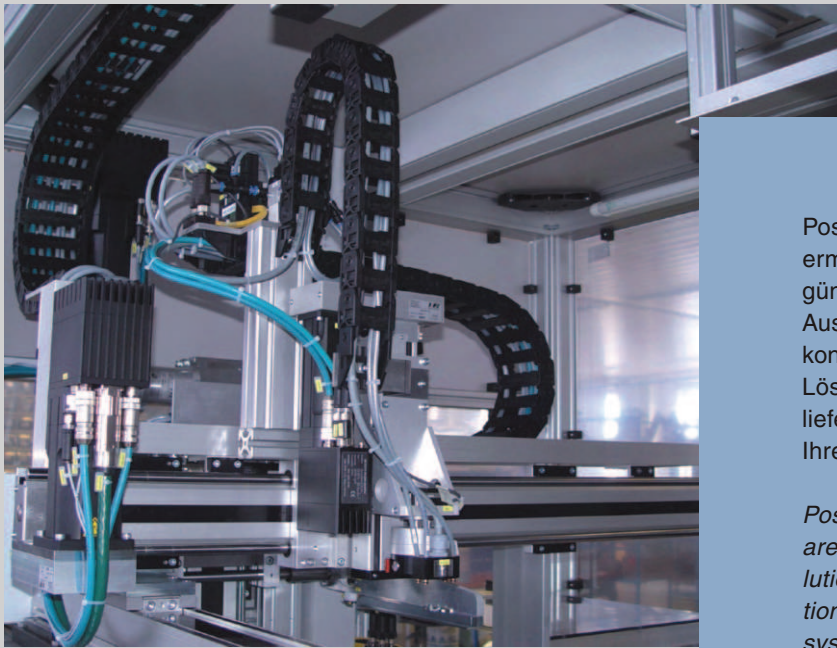

### Merkmale

- komplettes Produktprogramm für verschiedene Branchen und Anwendungen
- flexibel kombinierbar mit standardisierten Verbindungselementen
- umfangreicher Beratungsservice mit Motorauslegung und kostenloser Bereitstellung Ihrer individuellen Zeichnungsdaten in 2- und 3D CAD Datenformat
- variabler Lieferumfang: Von der einfachen, zum Anbau Ihrer eigenen Motoren vorbereiteten Lineareinheit bis hin zum mehrachsigen, komplett montierten Positioniersystem inklusive Motoren, Energieführungssystem, Kabelsatz, Verstärker und Steuerung

### Features

- *complete product range for various industrial sectors and applications*
- *easy to combine using with standard connecting elements*
- *extensive consultation with motor selection and supply of your individual drawing in 2 - and 3D CAD data formats for free*
- *variable delivery: From simple linear unit which is prepared for assembly of your own motors, to completely assembled multi axes positioning system. Including motors, energy chains, cable set, amplifiers and control*

Positioniersysteme mit Zahnriemenantrieb ermöglichen Ihnen effizient und kostengünstig Ihre Handhabungsaufgabe zu lösen. Ausgehend von unseren Standarddachskonfigurationen erhalten Sie Ihre individuelle Lösung. Kompetente Beratung und Komplettlieferrung garantieren eine schnelle Lösung Ihrer Anforderung.

*Positioning systems with toothed belt drive are the most efficient and cost-effective solution for your automated handling applications. By configuring your own positioning system that is fully proved and tested, the optimum solution can be assured, particularly with the support and input from our engineers. Complete systems comprise all the mechanical elements, the controller, motors, cables and energy chains.*

Produkt Product	Hub max. Stroke max.	Geschwindigkeit Speed max.	Belastung Load max.	
easyLINE 	5500 mm	2,5 m/s	15 kg	Die Einstiegsklasse / The basic class
Modul 105 	5500 mm	2 m/s	30 kg	
Modul 142 	5500 mm	2 m/s	60 kg	
Modul 65/15 	5500 mm	5 m/s	10 kg	Die Premiumklasse / The premium class
Modul 80/15 	5500 mm	5 m/s	10 kg	
Modul 115/42 	5500 mm	5 m/s	30 kg	
Modul 160/15 	5500 mm	5 m/s	80 kg	
Modul 68 	500 mm	1,5 m/s	5 kg	Die Auslegerachsen / The cantilever axis
Modul 90/15 	1000 mm	3 m/s	10 kg	
Modul 90/15 Teleskop 	1480 mm	3 m/s	5 kg	

# Die Einstiegsklasse

## The basic class



Die Einstiegsklasse der IEF Linearmodule ermöglicht preisgünstiges Positionieren für eine Vielzahl von Applikationen. Die tausendfach bewährten, robusten und wartungsarmen Linearmodule eignen sich hervorragend für Pick & Place Anwendungen bei denen Geschwindigkeit und Zykluszeit nicht die höchsten Anforderungen erfüllen müssen. Eine niedrige Bauhöhe und geringe Außenabmessungen ermöglichen platzsparende Konstruktionen.

*The basic class of the IEF linear modules enables budget priced positioning for a variety of applications. These proven, robust and low-maintenance positioning systems are ideal for Pick & Place applications where speed and cycle time are not within the highest requirements. A low overall height and minimum external dimensions provide space-saving designs.*

### Merkmale

- integrierte induktive Endlagenschalter zur Vermeidung von zusätzlichem Verdrahungsaufwand
- variabler Motoranbau erlaubt eine Anpassung an spezielle Gegebenheiten
- Verzahnung und Wellenansatz aus einem Stück, garantiert Spielfreiheit über die gesamte Lebensdauer
- alle Welle-Nabeverbindungen sind mit kraftschlüssigen Verbindungselementen ausgeführt
- umfangreiches Montagematerial erlaubt kostengünstiges Kombinieren

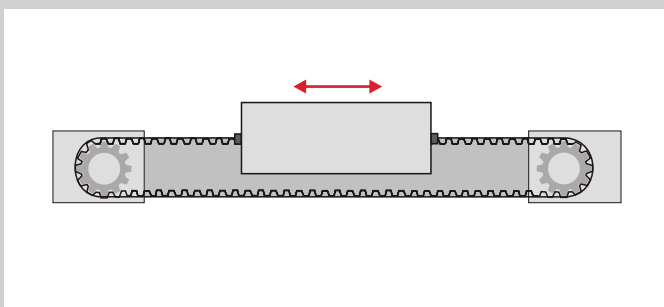

### Features

- integrated inductive limit switches to avoid additional wiring jobs
- variable motor attachment permits adaption on special conditions
- Tothing and shaft socket made of one part guarantees backlash free during the whole lifetime
- all shaft to collar connections are fitted by tied positively connection elements
- extensive assembly elements allows a cost effective combination



■ Antrieb mit umlaufendem Zahnriemen  
*Circular toothed belt drive*

**Technische Daten**  
**Technical Data**

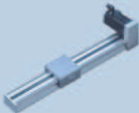
	 <b>easyLINE</b>	 <b>Modul 105</b>	 <b>Modul 142</b>
Hub (Hubabstufung 100 mm) <i>Stroke (Increments 100 mm)</i>	100-5500 mm	100-5500 mm	100-5500 mm
Gewicht bei 100 mm Hub <i>Weight at 100 mm stroke</i>	4,4 kg	4,4 kg	11,2 kg
Gewichtszunahme pro 100 mm Hub <i>Weight increase per 100 mm stroke</i>	0,45 kg	0,45 kg	1,25 kg
Maximale Verfahrgeschwindigkeit <i>maximum speed</i>	2 m/s	2 m/s	2 m/s
Wiederholgenauigkeit <i>Repeatability accuracy</i>	+/-0,04 mm	+/-0,04 mm	+/-0,04 mm
Zahnriemenbreite <i>Toothed belt wide</i>	25/AT5	25/AT5	50/T10
Seilzugfestigkeit Zahnriemen <i>Toothed belt - tension capacity</i>	1750	1750	4400
Flächenträgheitsmoment des Grundkörpers <i>Geometrical moment of inertia from the basic body</i>			
I <sub>x</sub>	242.056 mm <sup>4</sup>	451.984 mm <sup>4</sup>	932.661 mm <sup>4</sup>
I <sub>y</sub>	473.400 mm <sup>4</sup>	1.527.605 mm <sup>4</sup>	4.397.704 mm <sup>4</sup>
C <sub>1</sub>	1000 N	1500 N	3800 N
C <sub>2</sub>	550 N	700 N	2100 N
M <sub>x</sub>	35 Nm	50 Nm	240 Nm
M <sub>y</sub>	50 Nm	70 Nm	230 Nm
M <sub>z</sub>	20 Nm	35 Nm	110 Nm

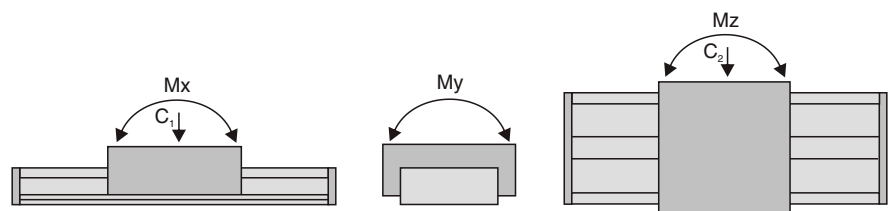

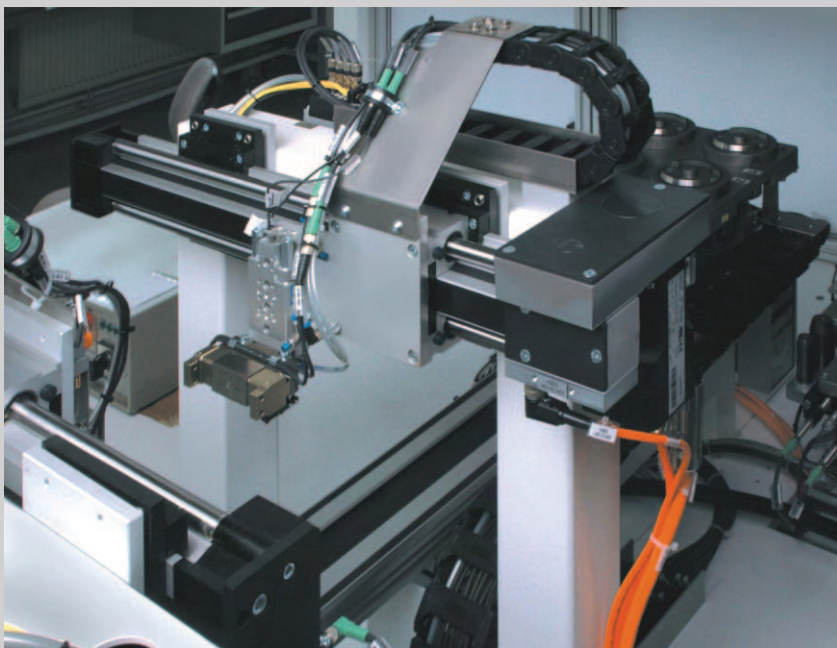

■  
 Pick&Place Aufbau easyLINE  
*Pick&Place assembly easyLINE*

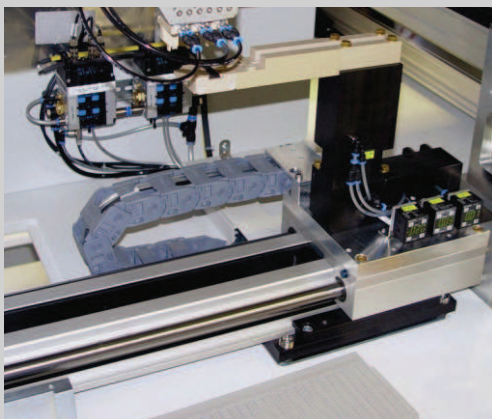

■  
 Zufuhreinheit für Sensoren  
*Feeding unit for sensors*

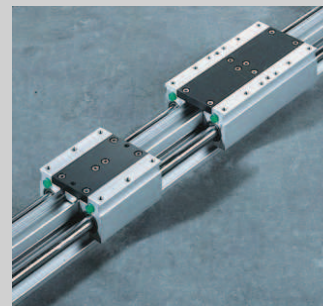

■  
 easyLINE,  
 2 verschiedene  
 Schlitteneinheiten  
 stehen zur Aus-  
 wahl  
*easyLINE,*  
*2 different slide*  
*units are available*

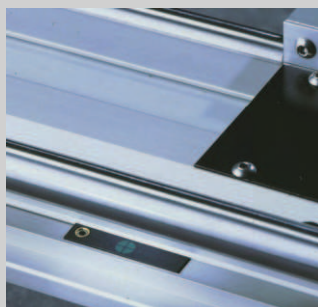

■  
 Die induktiven End-  
 begrenzungsschalter  
 sind - vor äußeren  
 Einflüssen geschützt -  
 in einem Kabelschacht  
 integriert  
*The inductive limit*  
*switches are integrated*  
*in a cable duct, protec-*  
*ted against external*  
*influences*

## Motoranbauvariante 1 / Motor attachment variant 1

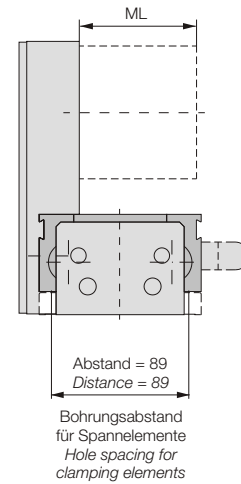
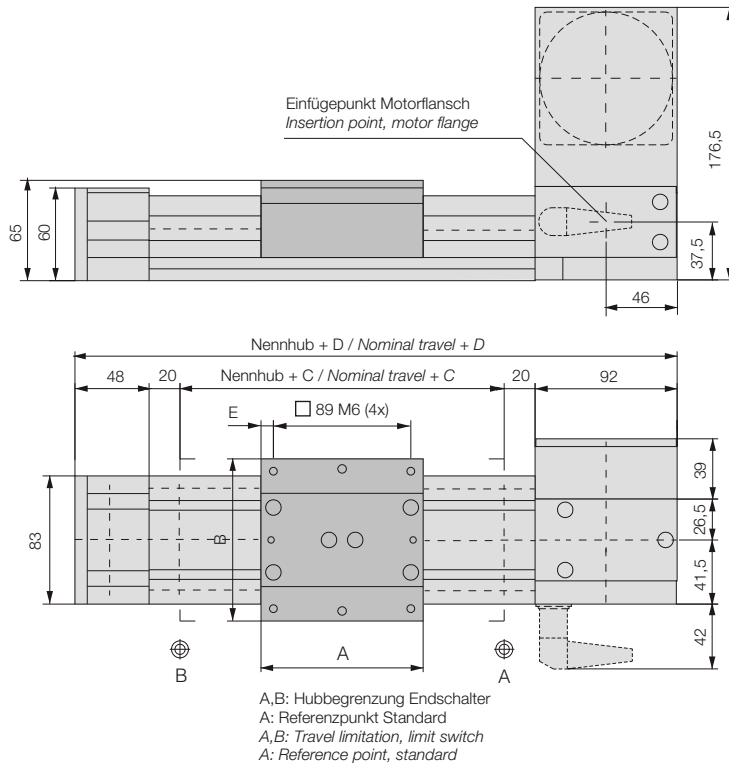

Typ	A	B	C	D	E
Standardschlitten Standard slide	105	105	110	290	8
Langschlitten Longitudinal slide	194	105	210	390	8/52,5/97

## Motoranbauvariante 5 / Motor attachment variant 5

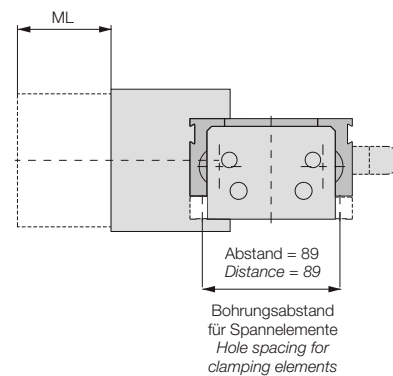
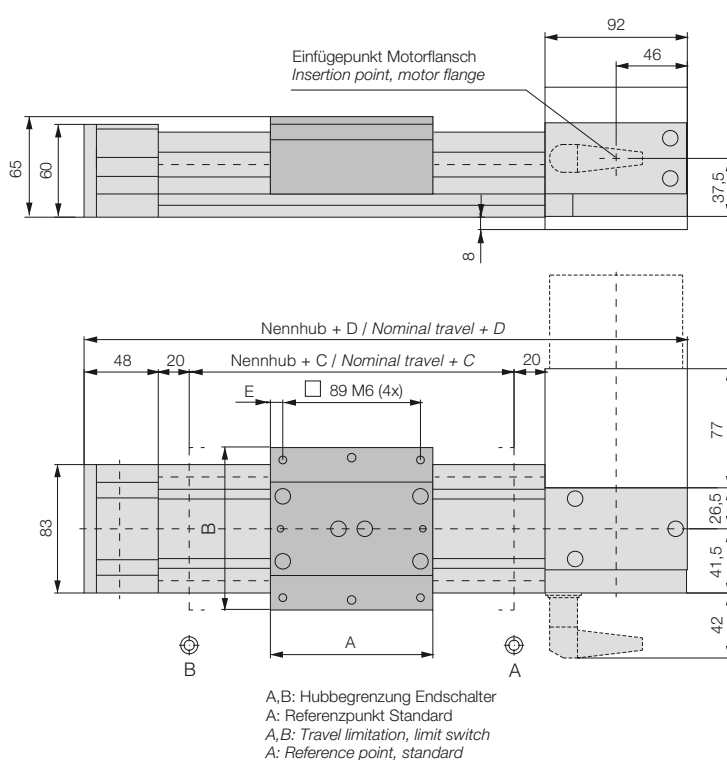

Typ	A	B	C	D	E
Standardschlitten Standard slide	105	105	110	290	8
Langschlitten Longitudinal slide	194	105	210	390	8/52,5/97

# Modul 105

## Motoranbauvariante 0 / Motor attachment variant 0

Bohrungsabstand für Spannelemente  
Hole spacing for clamping elements

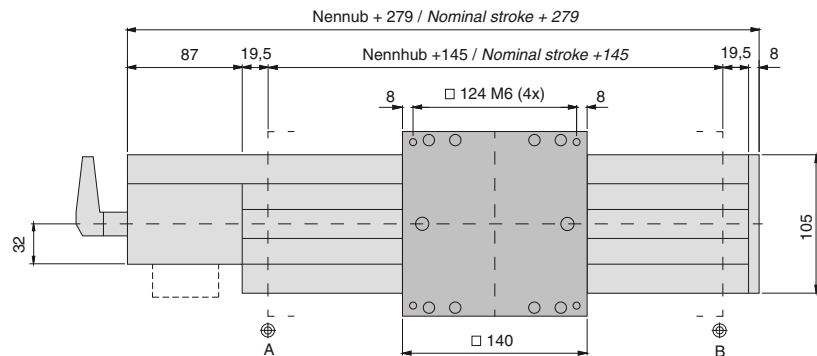
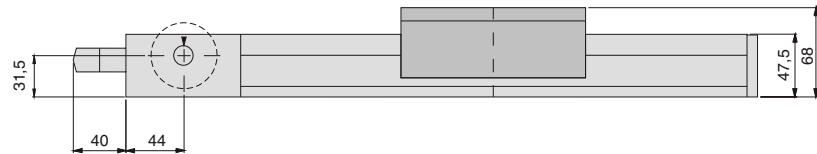
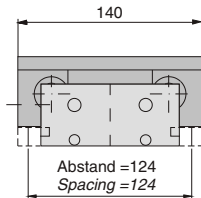

A,B: Hubbegrenzung Endschalter / Stroke limitation, limit switch  
A : Referenzpunkt Standard / Reference point, standard

## Motoranbauvariante 0 mit Faltenbalg / Motor attachment variant 0 with bellows boots

Bohrungsabstand für Spannelemente  
Hole spacing for clamping elements

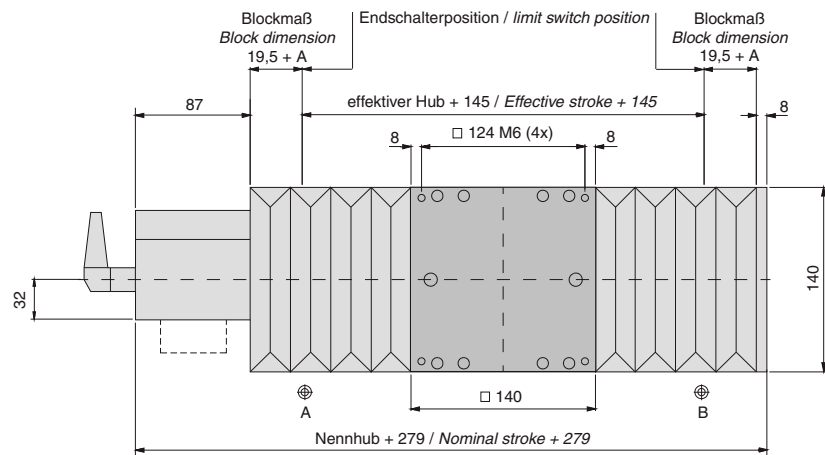
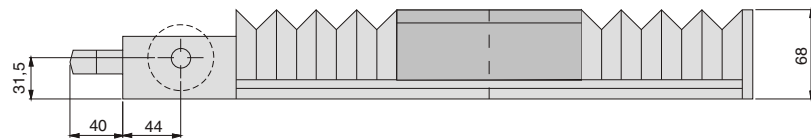
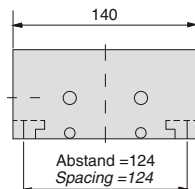

A,B: Hubbegrenzung Endschalter / Stroke limitation, limit switch  
A : Referenzpunkt Standard / Reference point, standard

Nennhub / Nominal stroke	100 mm	200 mm	300 mm	400 mm	500 mm	bis / up to →	5500 mm
Effektiver Hub / Effective stroke	80 mm	160 mm	240 mm	320 mm	400 mm	bis / up to →	4400 mm
Maß A / Dimension A	10 mm	20 mm	30 mm	40 mm	50 mm	bis / up to →	550 mm

# Modul 142

## Motoranbauvariante 0 / Motor attachment variant 0

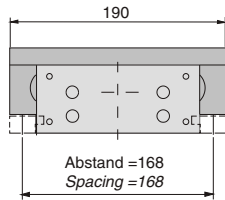

Bohrungsabstand für Spannelemente  
Hole spacing for clamping elements

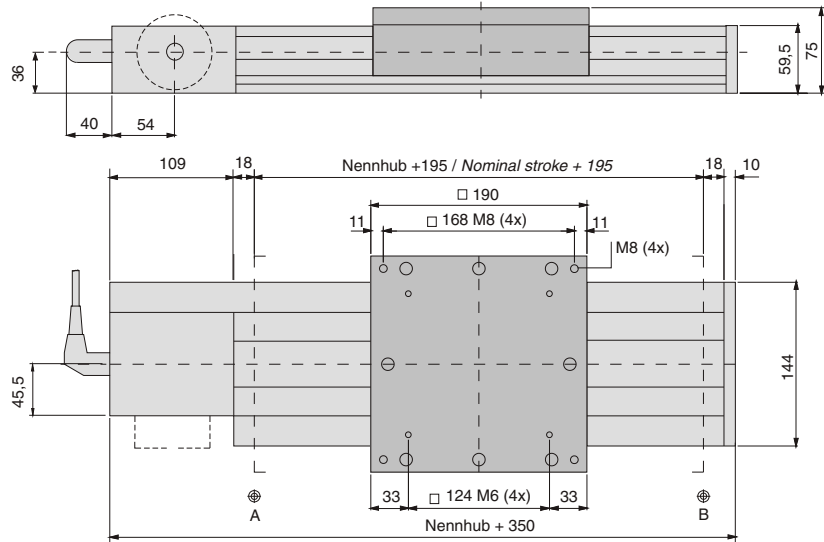

A,B: Hubbegrenzung Endschalter / Stroke limitation, limit switch  
A : Referenzpunkt Standard / Reference point, standard

## Motoranbauvariante 0 mit Faltenbalg / Motor attachment variant 0 with bellows boots

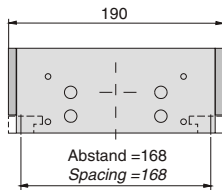

Bohrungsabstand für Spannelemente  
Hole spacing for clamping elements

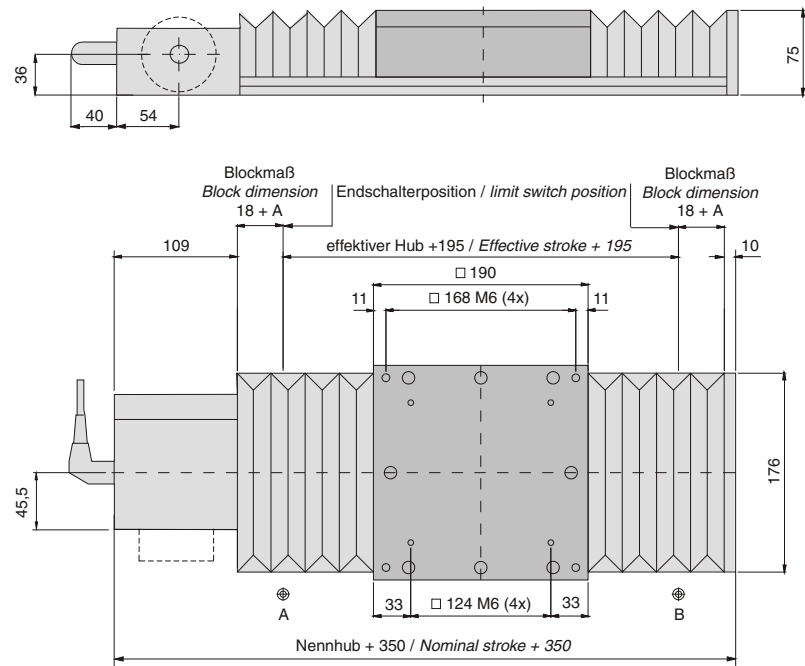

A,B: Hubbegrenzung Endschalter / Stroke limitation, limit switch  
A : Referenzpunkt Standard / Reference point, standard

Nennhub / Nominal stroke	100 mm	200 mm	300 mm	400 mm	500 mm	bis / up to →	5500 mm
Effektiver Hub / Effective stroke	75 mm	155 mm	235 mm	315 mm	395 mm	bis / up to →	4395 mm
Maß A / Dimension A	12,5 mm	22,5 mm	32,5 mm	42,5 mm	52,5 mm	bis / up to →	552,5 mm

- 1** Montagestütze Typ 105/140  
L = kundenspezifisch
- 2** Montagestütze Typ 105/105  
L = kundenspezifisch
- 3** Spannprofil, L = kundenspezifisch
- 4** Spannelement, Typ 105
- 5** Verbindungswelle, Parallelantrieb  
easyLINE, L = kundenspezifisch
- 6** Haltewinkel easyLINE
- 7** Winkelprofil easyLINE  
L = Kundenspezifisch

## Verbindungselemente Connecting elements

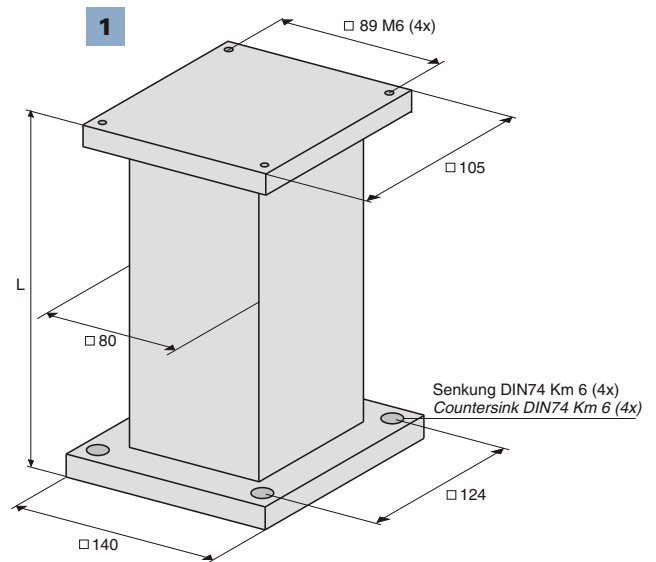

- 1** Mounting support, type 105/142  
L = customer-specific
- 2** Mounting support, type 105/105  
L = customer-specific
- 3** Clamping profile,  
L = customer-specific
- 4** Clamping element type 105
- 5** Connecting shaft, parallel drive  
easyLINE, L = customer-specific
- 6** Retaining bracket, easyLINE
- 7** Angle profile, easyLINE  
L = customer-specific

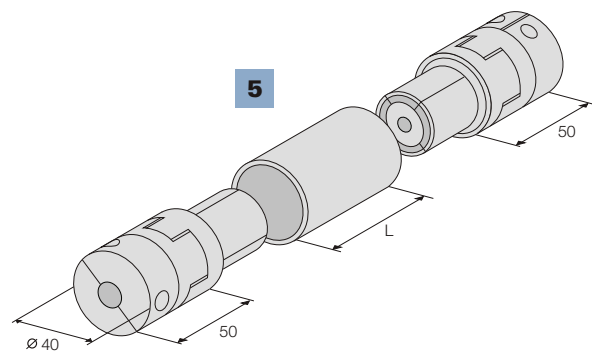

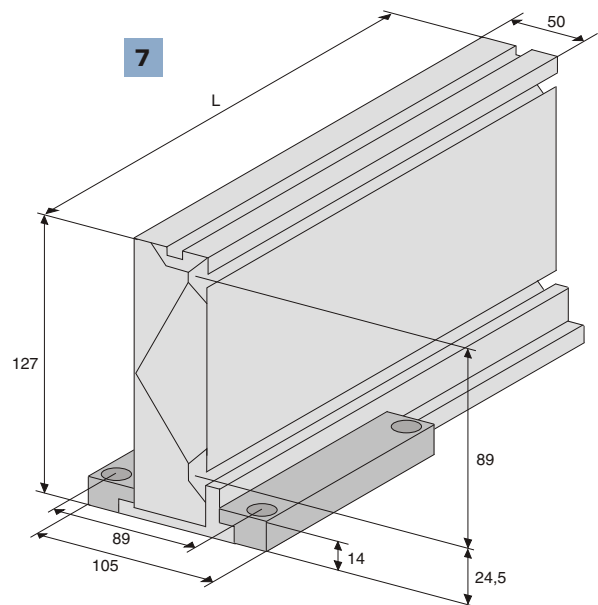
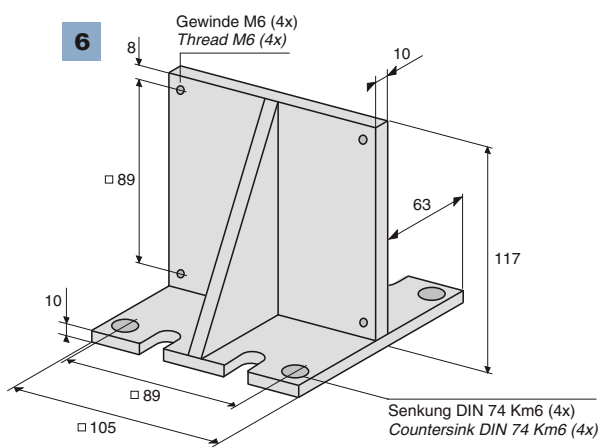
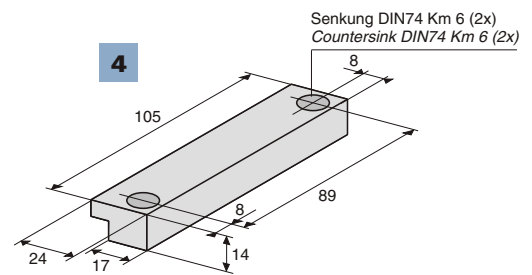
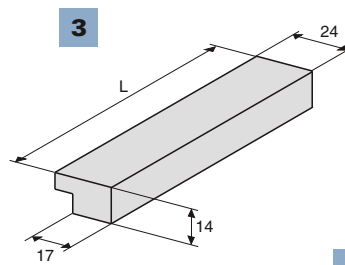
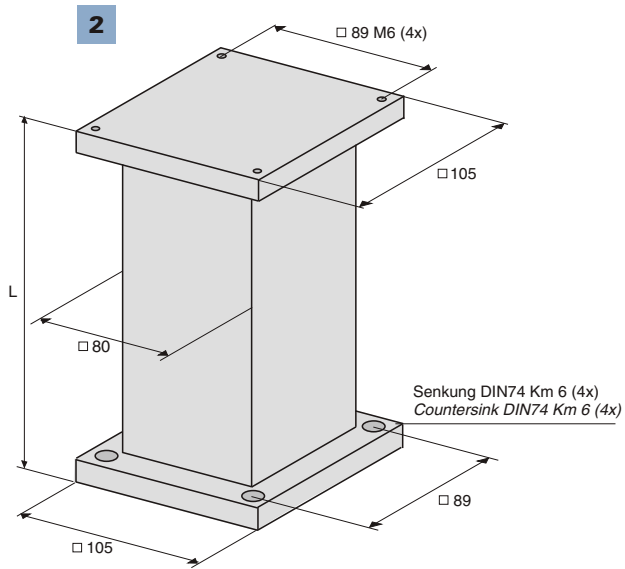

# Modul 105

- 1** Montagestütze Typ 105,  
L = kundenspezifisch
- 2** Spannelement Typ 16
- 3** Spannelement Typ 140
- 4** Spannprofil, L = kundenspezifisch
- 5** Verbindungswelle, Parallelantrieb  
Modul 105, L = kundenspezifisch
- 6** Haltewinkel mittig, Modul 105
- 7** Variabler Anschlag Modul 105,  
mit Gummipuffer
- 8** Stopper Typ 16, mit Gummipuffer

- 1** *Mounting support, Type 105,  
L = Customized*
- 2** *Clamping element, Type 16*
- 3** *Clamping element, Type 140*
- 4** *Clamping section,  
L = customized*
- 5** *Connecting shaft, parallel drive  
module 105, L = Customized*
- 6** *Retaining bracket, central,  
module 105*
- 7** *Variable stop, module 105,  
with rubber buffer*
- 8** *Stopper, Type 16,  
with rubber buffer*

## Verbindungselemente / Connecting elements

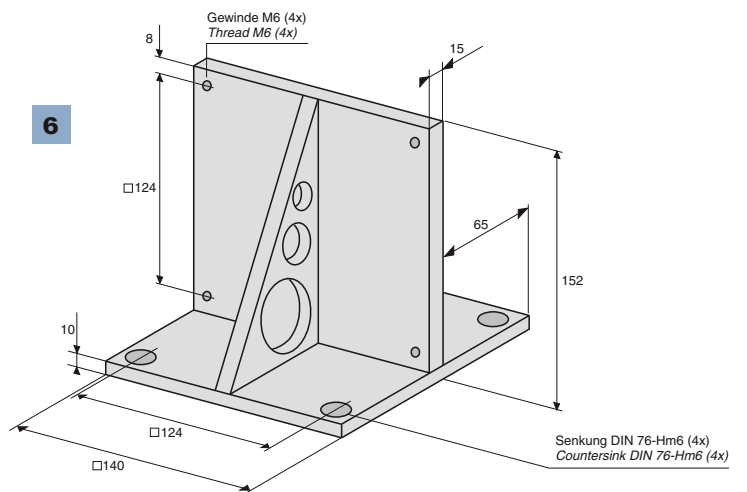
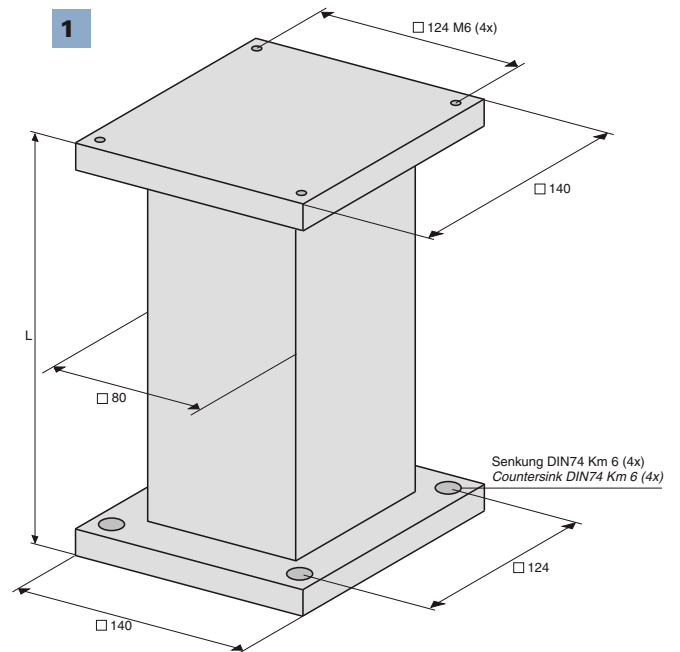

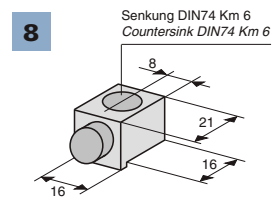
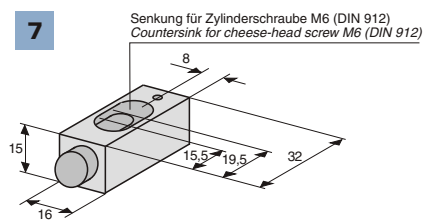
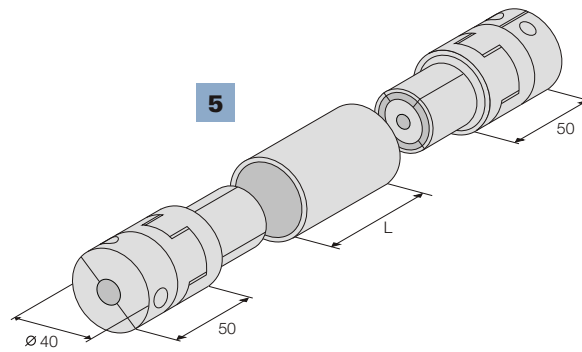
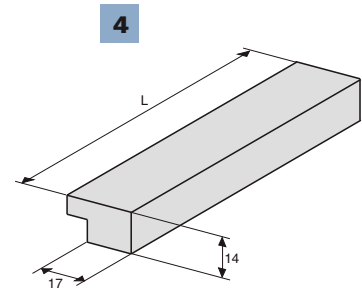
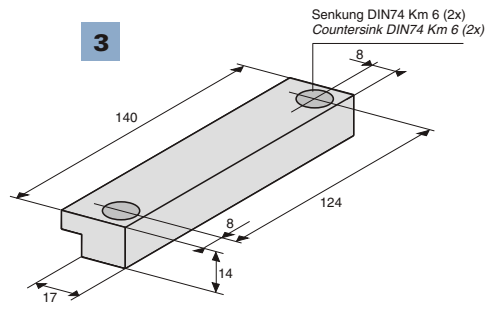
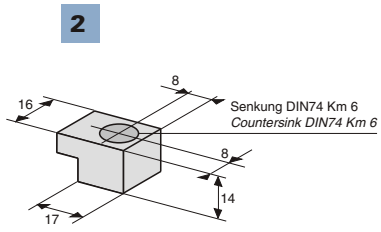

# Modul 142

- 1** Montagestütze Typ 142,  
L = kundenspezifisch
  - 2** Spannelement Typ 22
  - 3** Spannelement Typ 190,
  - 4** Spannprofil Modul 142,  
L = kundenspezifisch
  - 5** Verbindungswelle Parallelantrieb  
Modul 142, L = kundenspezifisch
  - 6** Haltewinkel mittig Modul 142
  - 7** Variabler Anschlag Modul 142, mit  
Gummipuffer
  - 8** Stopper Typ 22, mit Gummipuffer
- 
- 1** *Mounting support, Type 142,  
L = customized*
  - 2** *Clamping element, Type 22*
  - 3** *Clamping element, Type 190*
  - 4** *Clamping section, module 142,  
L = customized*
  - 5** *Connecting shaft, parallel drive  
module 142, L = Customized*
  - 6** *Retaining bracket, central,  
module 142*
  - 7** *Variable stop, module 102,  
with rubber buffer*
  - 8** *Stopper, Type 22, with rubber buffer*

## Verbindungselemente / Connecting elements

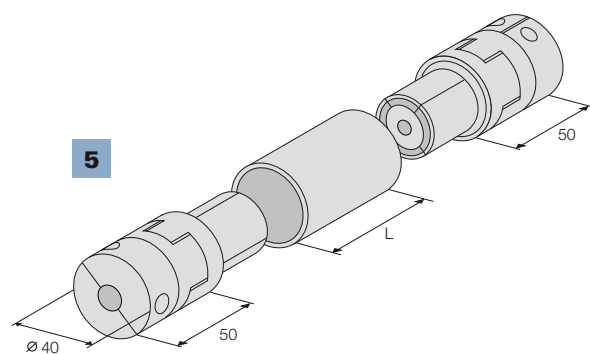
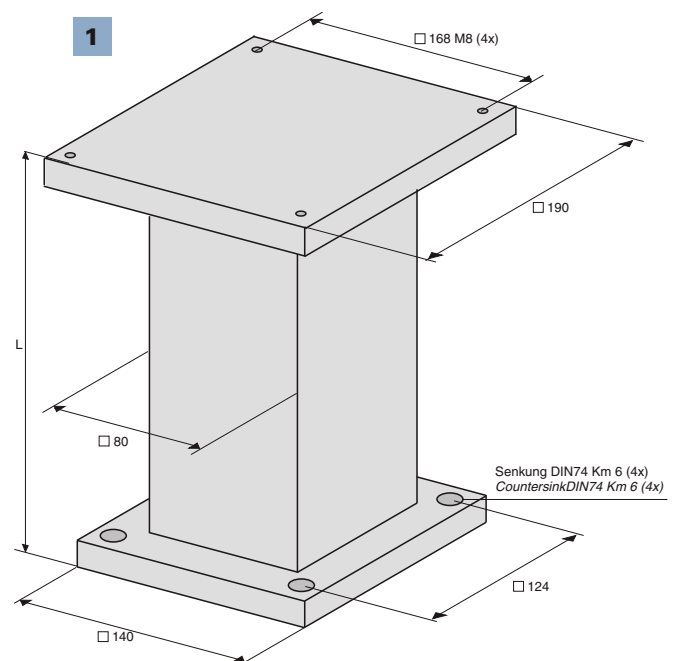

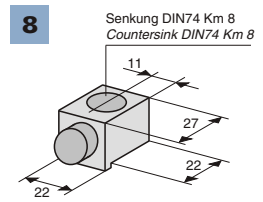
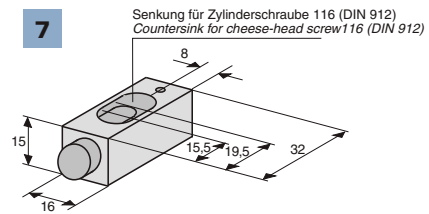
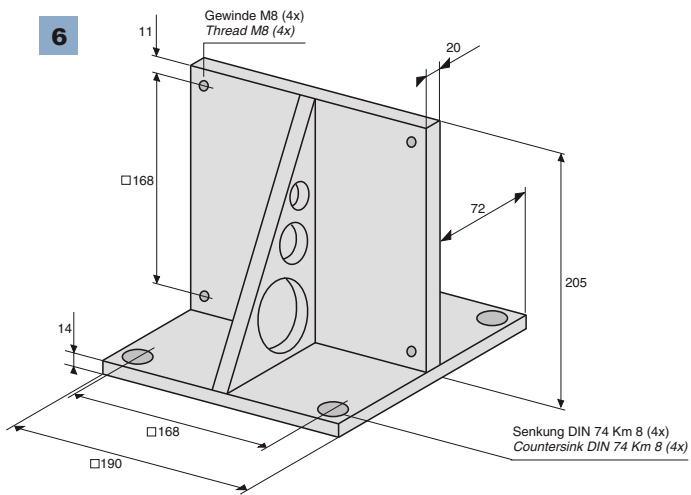
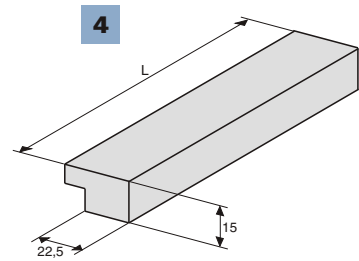
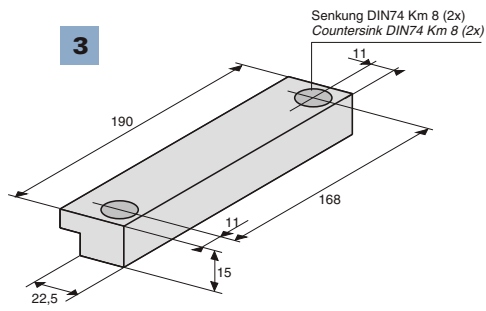
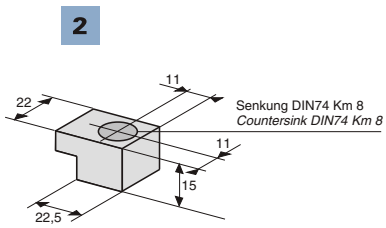

# Die Premium-Klasse

## *The premium class*

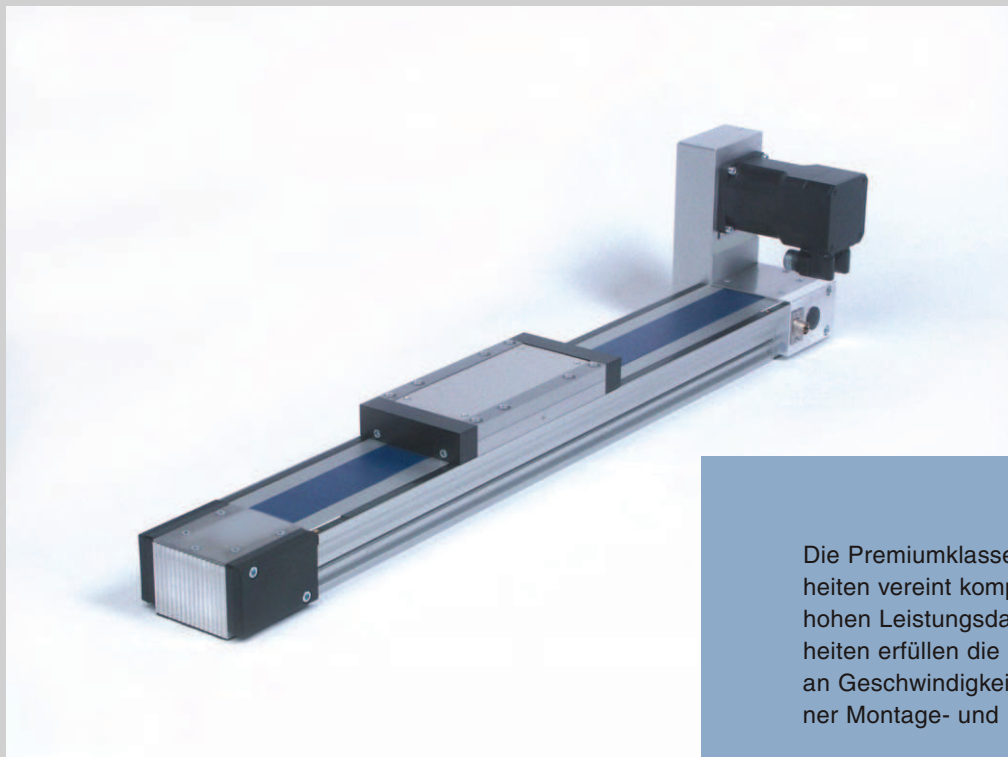

■  
Modul 115/42

Die Premiumklasse der IEF Lineareinheiten vereint kompakte Bauformen mit hohen Leistungsdaten. Diese Lineareinheiten erfüllen die hohen Anforderungen an Geschwindigkeit und Präzision moderner Montage- und Produktionsanlagen.

*The premium class of the IEF linear units combine compact design with high performance characteristics.*

*The single- or multiple axes systems meet the high standards of speed and precision of modern assembly and production lines.*

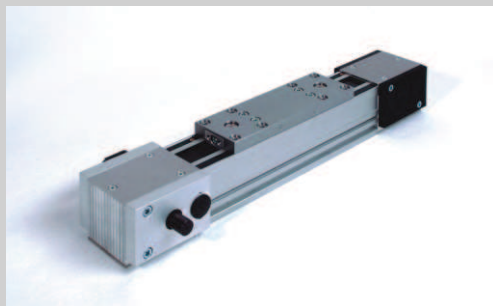

■  
Modul 65/15

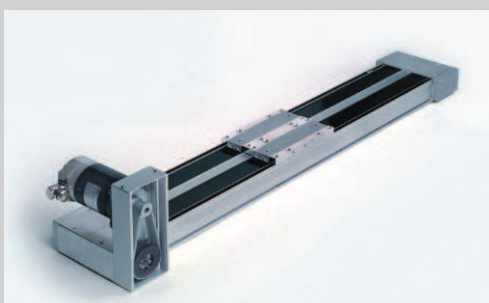

■  
Modul 160/15

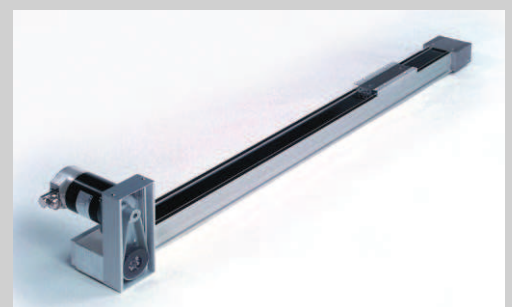

■  
Modul 80/15

## **Merkmale**

- Aluminium Hohlkammer-Strangpressprofil garantiert große Torsions- und Biegesteifigkeit
- Integrierte Führung ermöglicht Einsatz auch in mäßig verschmutzter Umgebung
- Führungselemente bis 10.000 km wartungsfrei
- Leiser Lauf durch Kugelkettentechnologie
- Welle-Nabe-Verbindungen ohne Passfeder garantieren lebenslange Spielfreiheit bei höchster Präzision
- 50 mm breiter Zahnriemen ermöglicht hohe Beschleunigung und Geschwindigkeit mit kurzen Taktzeiten
- Integrierte induktive Endlagenschalter auf einem einzigen Stecker sichern minimalen Verdrahtungs- und Installationsaufwand, zusätzlicher Referenzpunktschalter auf Wunsch
- Einfaches Befestigen mit Spannelementen erlaubt kostengünstigen und rationellen Aufbau von mehrachsigen Handlingsystemen



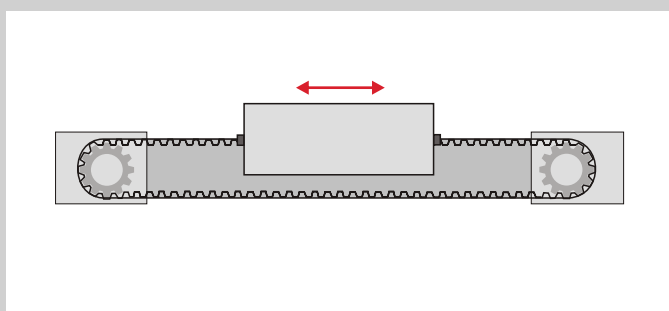

## **Features**

- *Aluminium extruded section in hollow chamber design guarantees high torsional and deflection strength*
- *Integrated guide rails allows operation in moderate polluted environment*
- *Guiding elements are maintenance free until an operational performance of 10.000 km*
- *Silent run using ball bearing chain technology*
- *Shaft to collar connections without featherkey guarantees lifetime zero backlash at highest precision*
- *50 mm wide toothed belt allows high acceleration and speed with short cycle times*
- *Integrated inductive limit switches saves wiring and installation costs. Additional reference switch on demand*
- *Easy assembly by using clamping elements permits cost effective installation of multi axes handling systems*

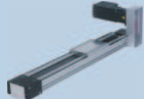

■ Antrieb mit umlaufendem Zahnriemen  
*Circular toothed belt drive*

**Technische Daten**  
**Technical Data**

	 <b>Modul 65/15</b>	 <b>Modul 80/15</b>	 <b>Modul 115/42</b>	 <b>Modul 160/15</b>
Hub (Hubabstufung 100 mm) <i>Stroke (Increments 100 mm)</i>	100-5500 mm	100-5500 mm	100-2750 mm	100-5500 mm
Gewicht bei 100 mm Hub <i>Weight at 100 mm stroke</i>	6 kg	5,7 kg	9,8 kg	9,8 kg
Gewichtszunahme pro 100 mm Hub <i>Weight increase per 100 mm stroke</i>	0,7 kg	0,6 kg	0,95 kg	1,05 kg
Maximale Verfahrgeschwindigkeit <i>maximum speed</i>	5 m/s	5 m/s	5 m/s	5 m/s
Wiederholgenauigkeit <i>Repeatability accuracy</i>	+/-0,05 mm	+/-0,05 mm	+/-0,05 mm	+/-0,05 mm
Zahnriemenbreite <i>Toothed belt wide</i>	32 mm	50 mm	50 mm	50 mm
Seilzugfestigkeit Zahnriemen <i>Toothed belt - tension capacity</i>	2800 N	4200 N	4200 N	4200 N
Flächenträgheitsmoment des Grundkörpers <i>Geometrical moment of inertia from the basic body</i>				
I <sub>x</sub>	595.678 mm <sup>4</sup>	570.018 mm <sup>4</sup>	677.502 mm <sup>4</sup>	1.196.016 mm <sup>4</sup>
I <sub>y</sub>	873.774 mm <sup>4</sup>	1.400.047 mm <sup>4</sup>	1.868.985 mm <sup>4</sup>	8.689.482 mm <sup>4</sup>
C <sub>1</sub>	1000 N	1000 N	2000 N	2000 N
C <sub>2</sub>	300 N	300 N	800 N	1000 N
M <sub>x</sub>	80 Nm	80 Nm	150 Nm	150 Nm
M <sub>y</sub>	30 Nm	30 Nm	80 Nm	150 Nm
M <sub>z</sub>	100 Nm	100 Nm	150 Nm	150 Nm

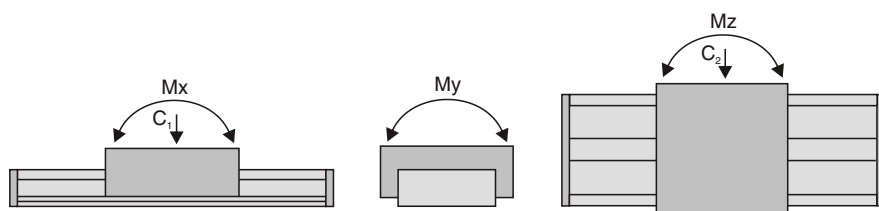

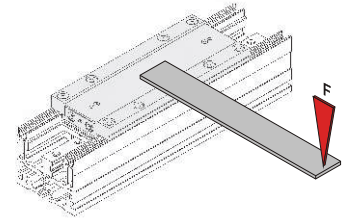
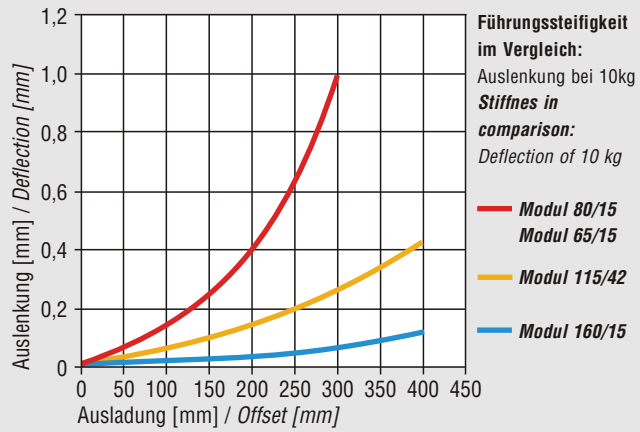

■ Führungssteifigkeit, abkippen des Schlittens  
*Deflection strength, cantilever load*

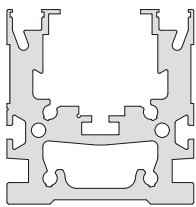

■ Querschnitt Modul 65/15  
*Sectional view Modul 65/15*

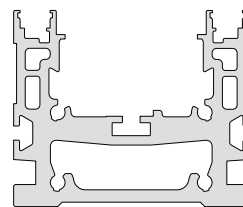

■ Querschnitt Modul 80/15  
*Sectional view Modul 80/15*

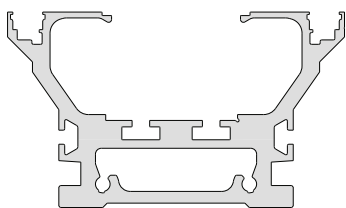

■ Querschnitt Modul 115/42  
*Sectional view Modul 115/42*

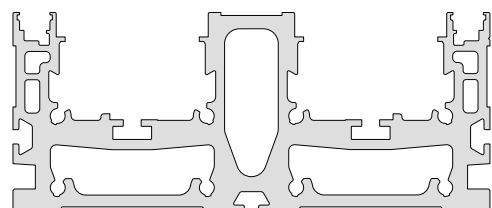

■ Querschnitt Modul 160/15  
*Sectional view Modul 160/15*



# Modul 80/15

## Motoranbauvariante 1 / Motor connecting variant 1

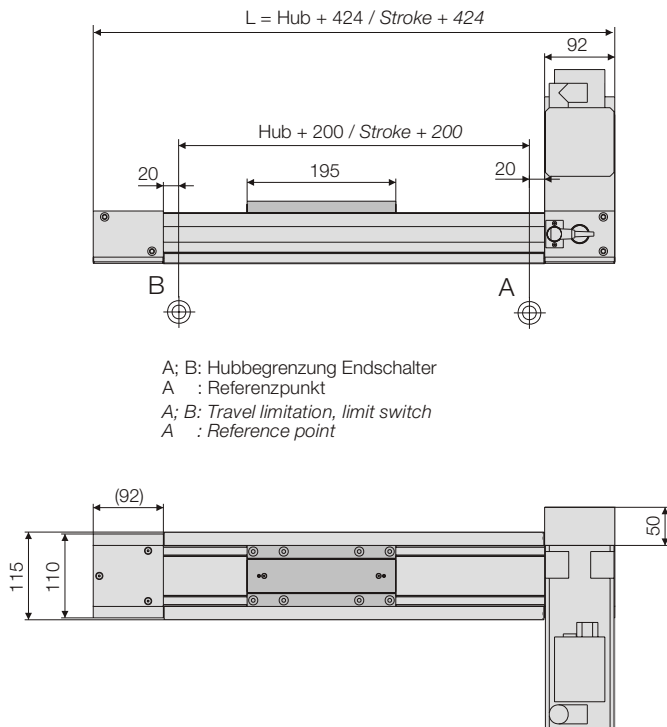

A; B: Hubbegrenzung Endschalter  
 A : Referenzpunkt  
 A; B: Travel limitation, limit switch  
 A : Reference point

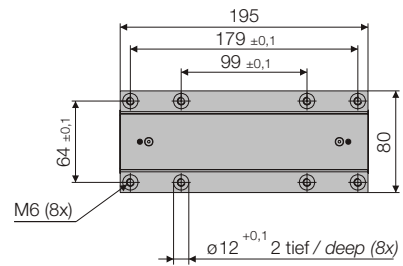
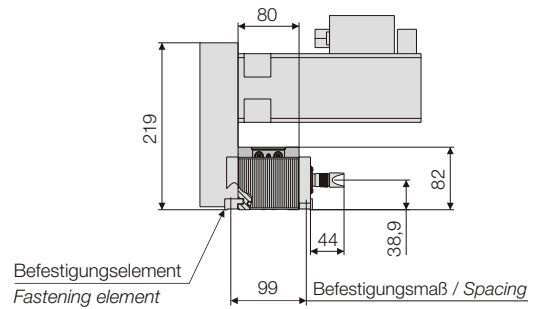

## Motoranbauvariante 5 / Motor connecting variant 5

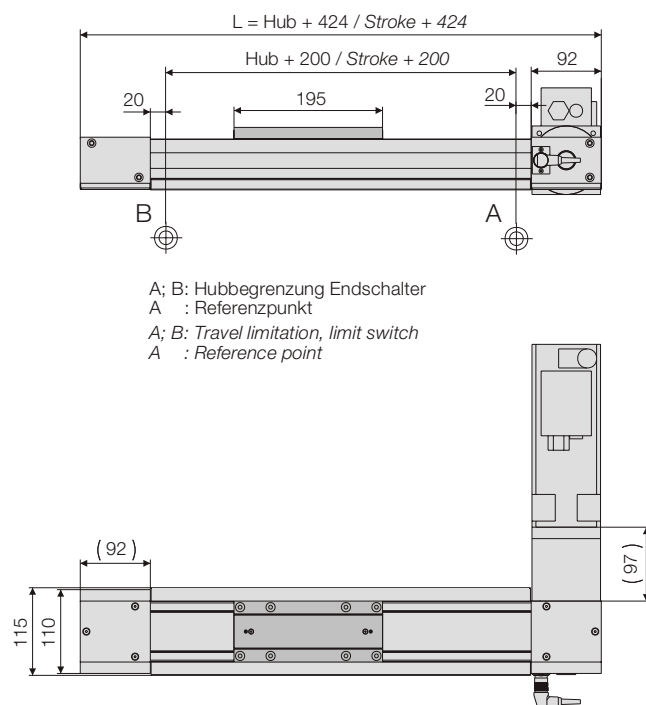

A; B: Hubbegrenzung Endschalter  
 A : Referenzpunkt  
 A; B: Travel limitation, limit switch  
 A : Reference point

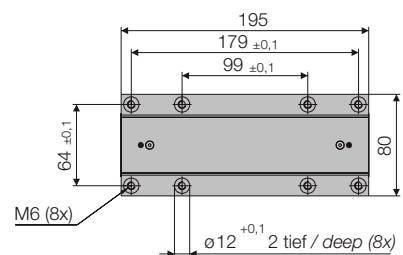
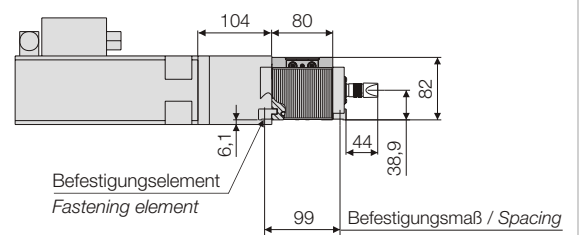

# Modul 115/42

## Motoranbauvariante 1 / Motor connecting variant 1

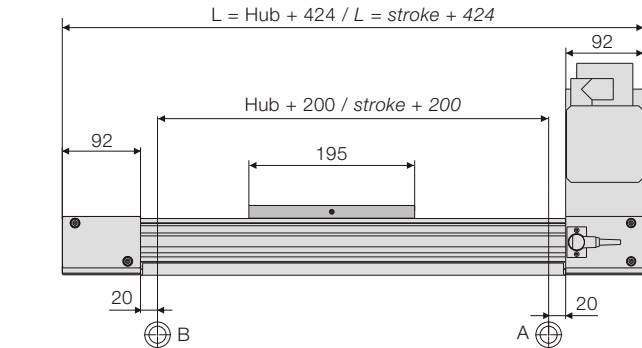

A; B: Hubbegrenzung Endschalter  
 A : Referenzpunkt  
 A; B: Travel limitation, limit switch  
 A : Reference point

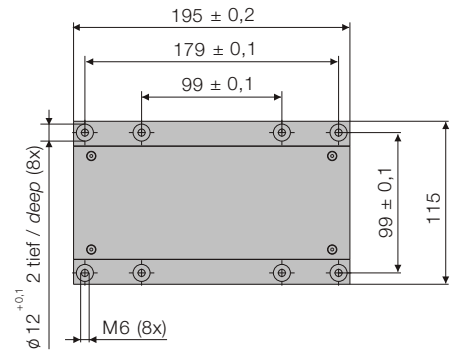
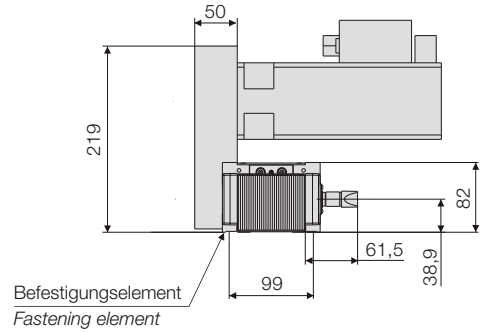
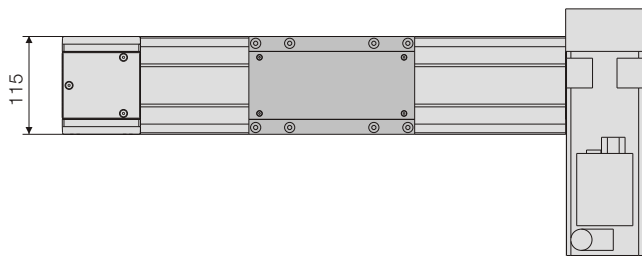

## Motoranbauvariante 5 / Motor connecting variant 5

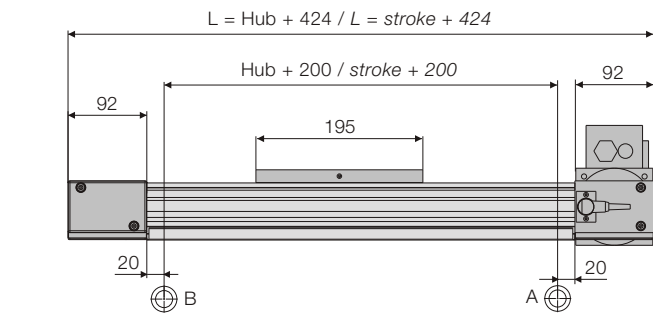

A; B: Hubbegrenzung Endschalter  
 A : Referenzpunkt  
 A; B: Travel limitation, limit switch  
 A : Reference point

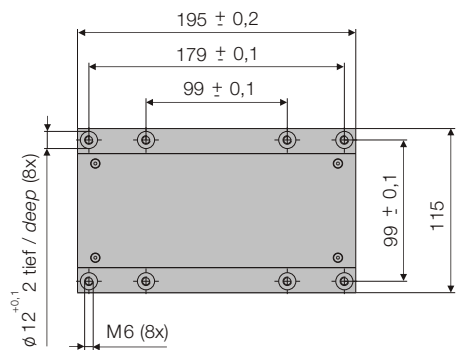
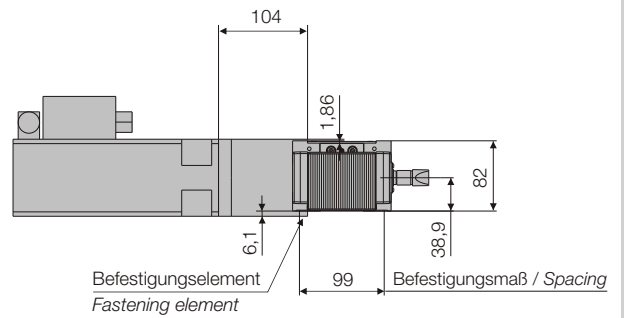
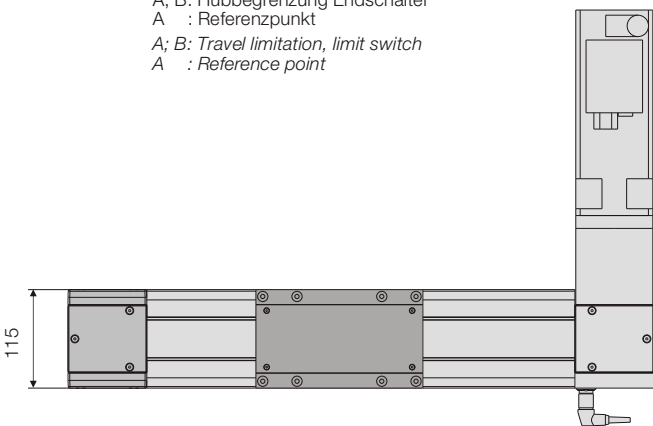

# Modul 160/15

## Motoranbauvariante 1 / Motor connecting variant 1

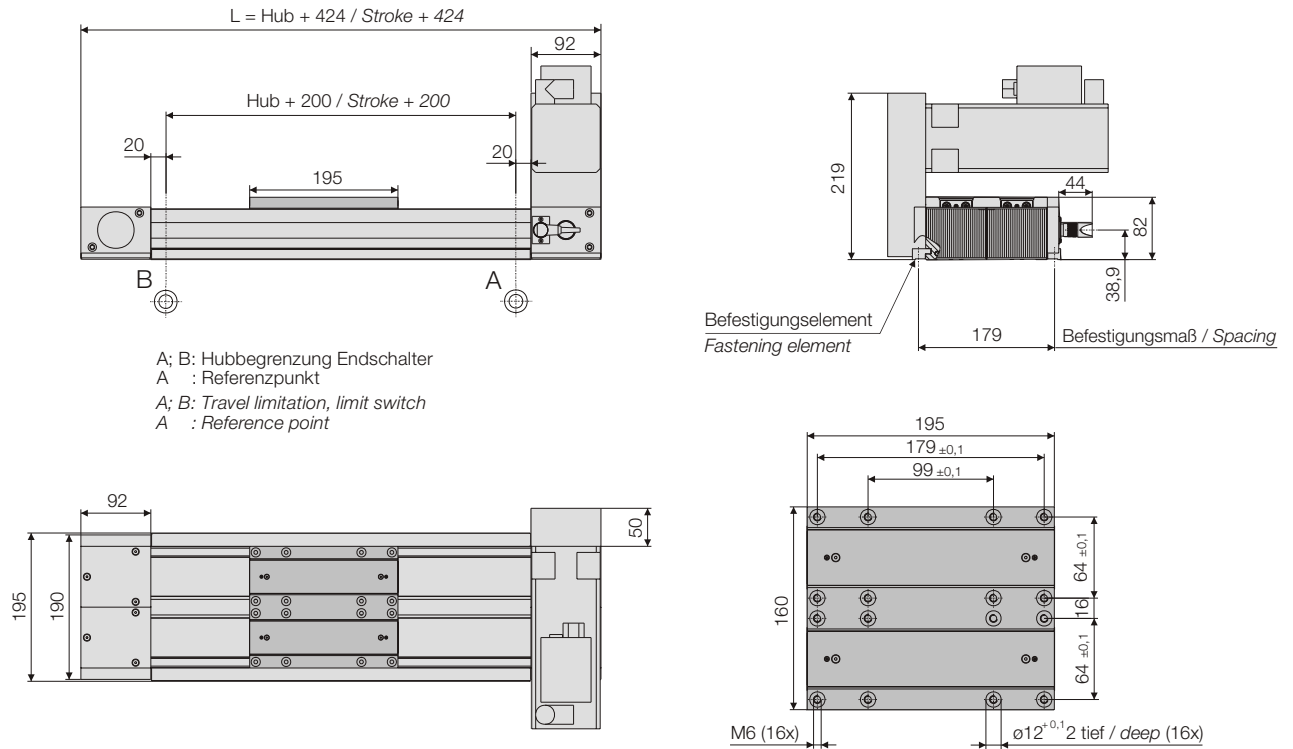

## Motoranbauvariante 5 / Motor connecting variant 5

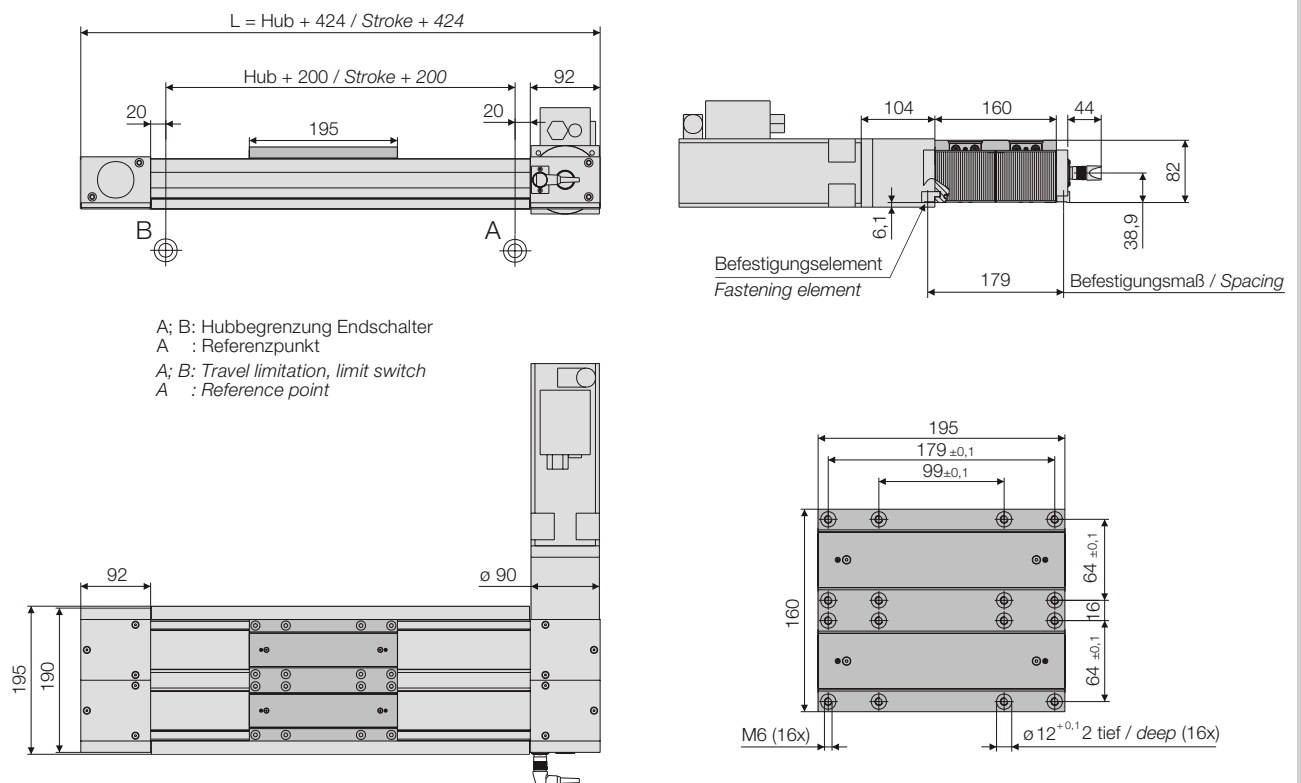

# Verbindungselemente Connecting elements

## Spannelemente / Clamping elements

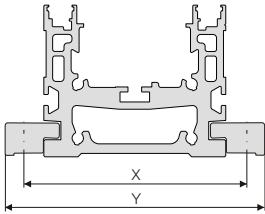

Querschnittmaße / Cross-section	X	Y
Modul 65/15, 80/15, 115/42	99	115
Modul 160/15	179	195

Maße Montagstütze Dim. mounting support	A	B	C	D
Modul 65/15	84	100	89	105
Modul 80/15, 115/42	89	105	99	115
Modul 160/15	124	140	179	195

## Spannelemente / Clamping elements

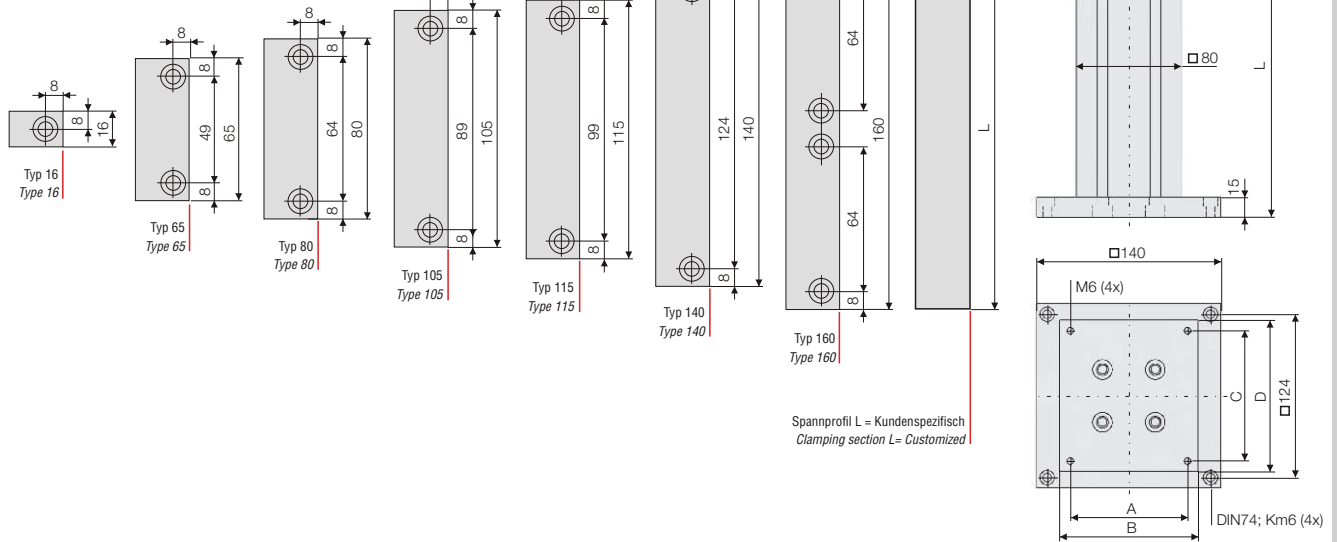

Verbindungswelle Parallelantrieb  
Modul 65/15 und Modul 80/15  
L = kundenspezifisch /  
Connecting shaft parallel drive  
Modul 65/15 and Modul 80/15  
L = Customized

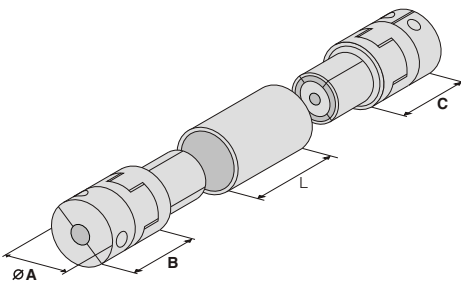

Maße [mm] Dimensions [mm]	A	B	C
Modul 65/15	40	50	50
Modul 80/15	50	62,5	62,5

Haltewinkel Modul 160/15  
Retaining bracket Modul 160/15

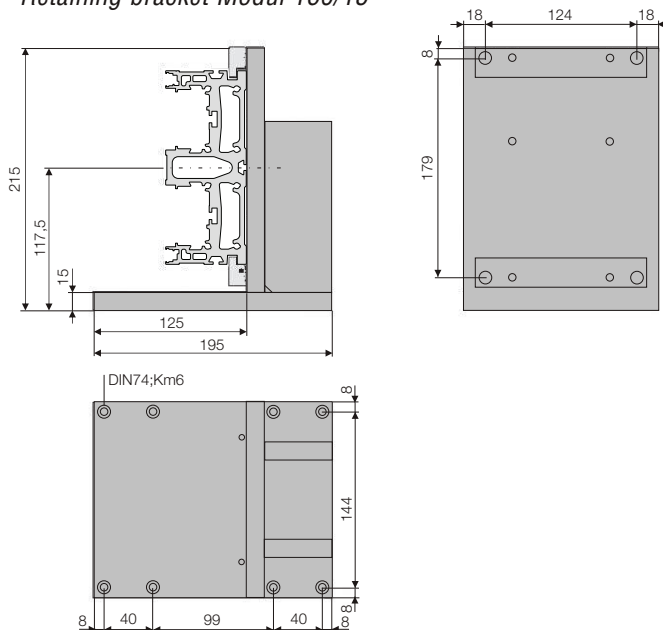

Haltewinkel links Modul 65/15 mit 115/42  
Retaining bracket left side Modul 65/15 with 115/42

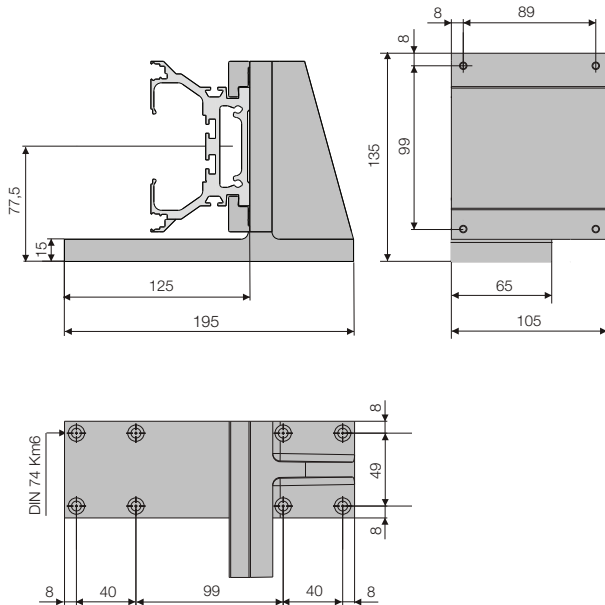

Haltewinkel rechts Modul 65/15 mit 115/42  
Retaining bracket right side Modul 65/15 with 115/42

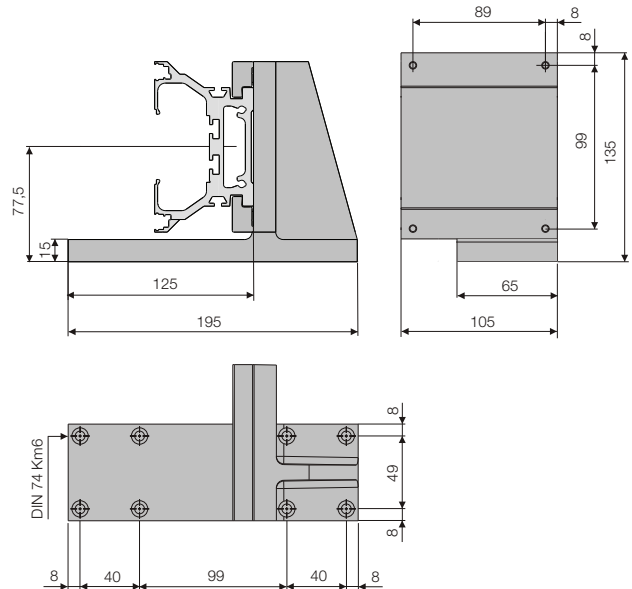

Haltewinkel links Modul 80/15 mit Modul 160/15  
Retaining bracket left side Modul 80/15 with Modul 160/15

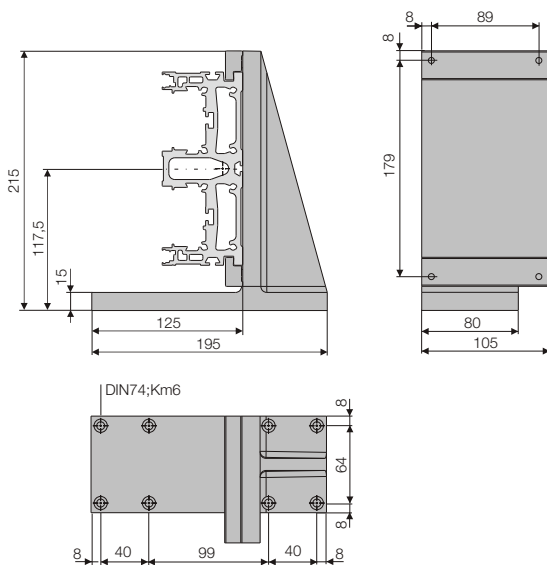

Haltewinkel rechts Modul 80/15 mit Modul 160/15  
Retaining bracket right side Modul 80/15 with Modul 160/15

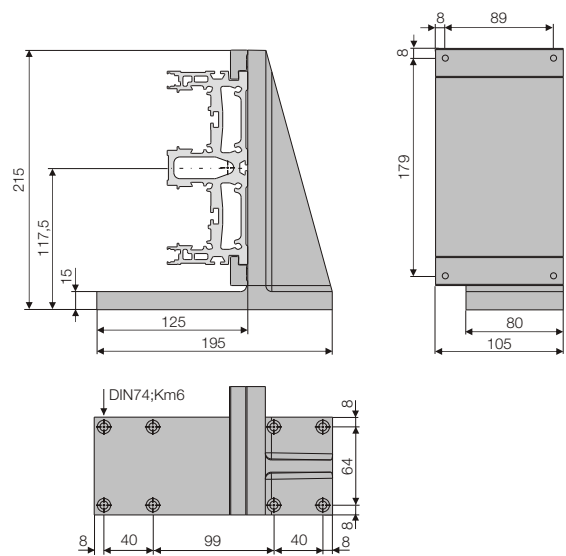

# Die Auslegerachsen *The cantilever axis*

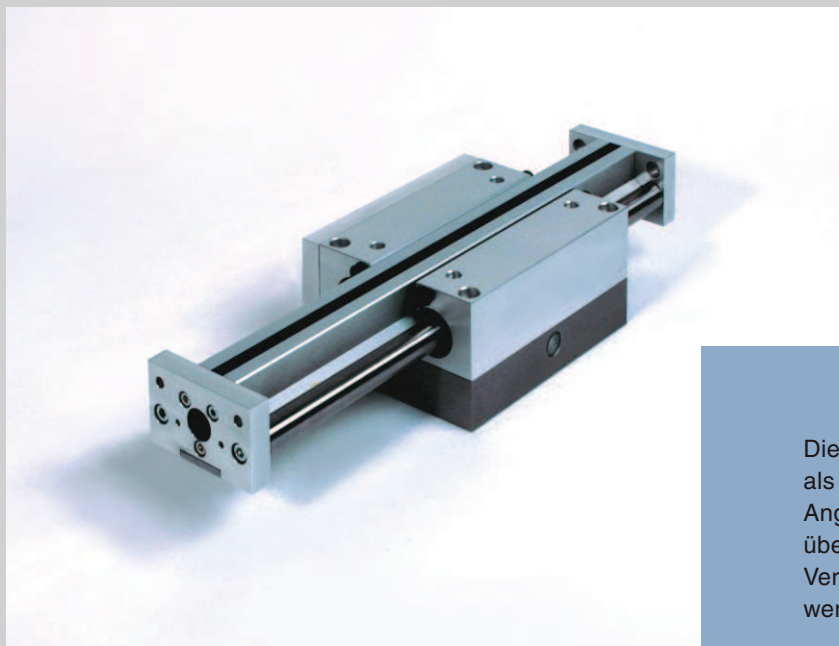

Die Module 68, und 90/15 sind besonders als Ausleger- oder Vertikalachse geeignet. Angetrieben werden die Module direkt oder über ein Riemengetriebe, wodurch auch im Vertikalbetrieb größere Lasten bewegt werden können.

*The modules of Series 68 and 90/15 are particularly suitable for use as cantilever or vertical axes. Module 68 is driven either directly or via a belt transmission, thus permitting heavier loads to be moved even in vertical mode.*

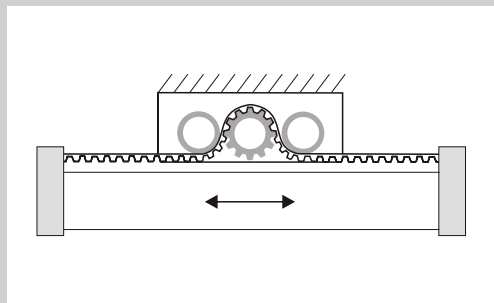

■  
Antrieb mit stehendem Zahnriemen  
*Drive with stationary toothed belt*

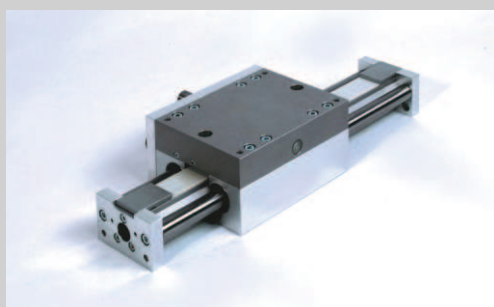

■  
Modul 68

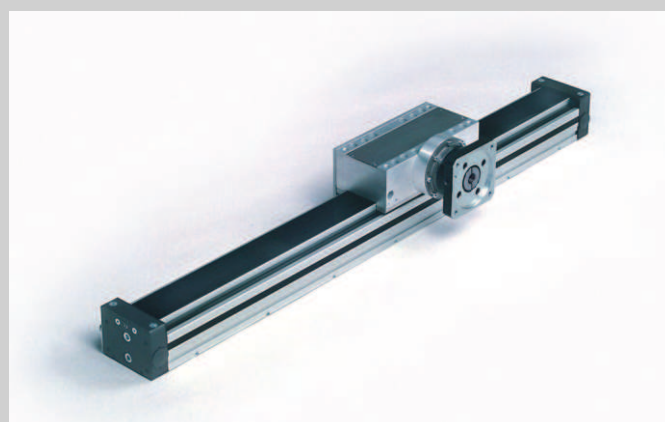

■  
Modul 90/15

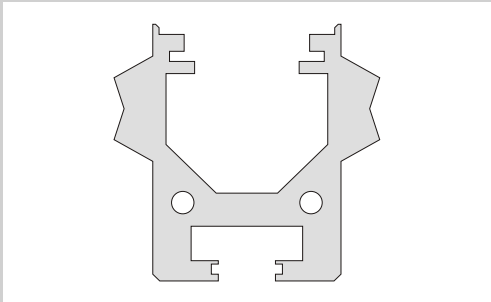

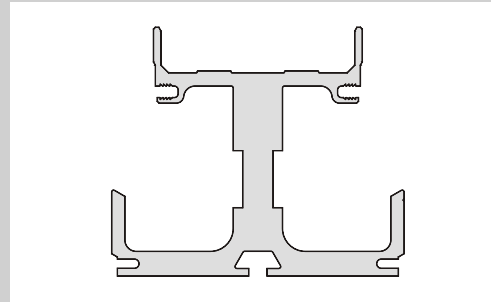

■ Querschnitt Modul 68  
Sectional view Module 68

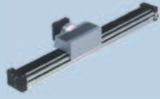

■ Querschnitt Modul 90/15  
Sectional view Module 90/15

### Technische Daten / Technical Data

	 Modul 68	 Modul 90/15
Hub (Abstufung 60 mm) / Stroke (Increments 60 mm)	100-500 mm	40-1000 mm
Gewicht (bei 60 mm Hub) / Weight (at 60 mm stroke)	4,55 kg	7,6 kg
Gewichtszunahme / Weight increase	0,45 kg / 100 mm	0,6 kg / 60 mm
maximale Verfahrensgeschwindigkeit / maximum speed		3 m/s
Wiederholgenauigkeit / Repeatability accuracy	+/-0,04 mm	+/-0,05 mm
Zahnriemenbreite / Toothed belt wide	25 mm	50 mm
Seilzugfestigkeit Zahnriemen / Toothed belt - tension capacity	1750 N	4200 N
Flächenträgheitsmoment Grundkörper / Geometrical moment of inertia basic body:		
I <sub>x</sub>	55279 mm <sup>4</sup>	445.755 mm <sup>4</sup>
I <sub>y</sub>	72349 mm <sup>4</sup>	521.756 mm <sup>4</sup>
Vorschubkonstante o. Getriebe / Forw. feed constant without gear	80 mm	140
Standardgetriebeuntersetzungen / Available gear reductions	Zahnriemengetriebe / Tooth belt gear 1:1, 2:1, 2,5:1	Zahnriemengetriebe / Tooth belt gear -
	Planetengetriebe / Planet gear 1:3, 1:4, 1:5, 1:8, 1:9, 1:12, 1:15	Planetengetriebe / Planet gear 5:1, 8:1, 16:1
max. Last im Vertikalbetrieb / max. load in vertical movement	5 kg	15 kg

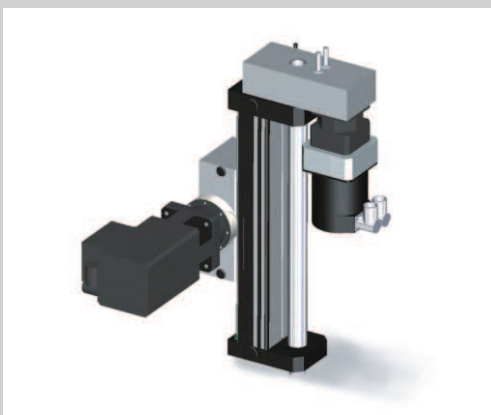

■ Modul 90/15 mit zusätzlicher Drehachse  
Modul 90/15 with additional rotary axis

### Optionen

- Integrierbare motorische Drehachse:
  - Drehwinkel 0 – 440°
  - Hohlwelle zur Durchführung von Kabeln und Schläuchen

### Options

- Integrable motor rotary axis:
  - Rotation angle: 0 - 440°
  - Hollow shaft for feedthrough of cables and tubes

# Belastungen

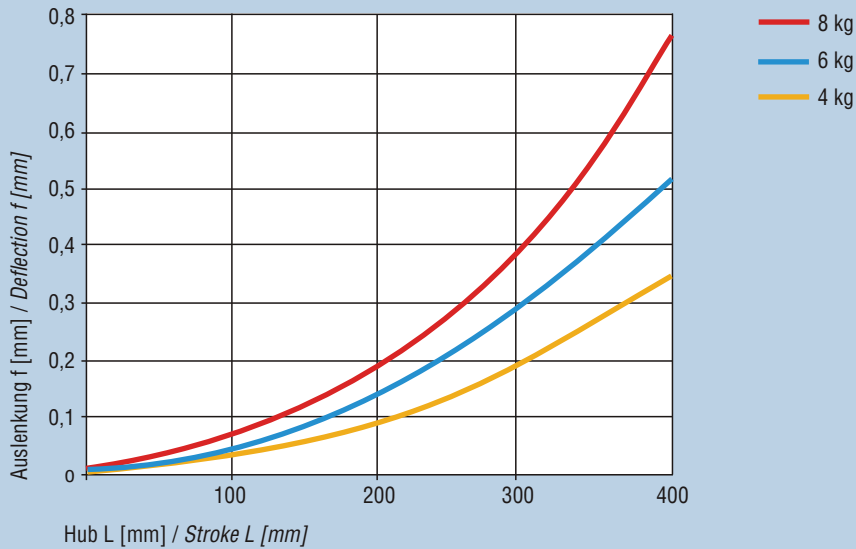

■ Biegesteifigkeit Modul 68  
Deflection strength Modul 68

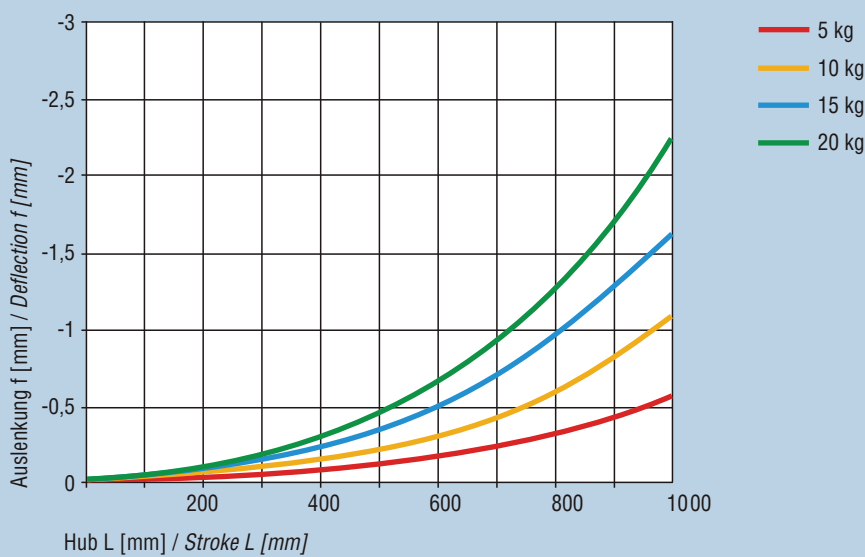

■ Biegesteifigkeit Modul 90/15  
Deflection strength Modul 90/15

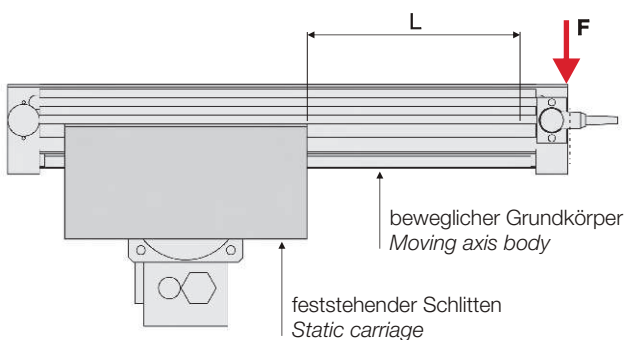

## Max. Belastung im Auslegerbetrieb Max. loads in extension operation

Modul 68						
F [N]	120	85	70	55	40	
L [mm]	100	200	300	400	500	
Modul 90/15						
F [N]	680	290	170	110	70	40
L [mm]	100	280	460	640	820	1000

# Modul 68

## Motoranbauvariante 1 / Motor attachment variant 1

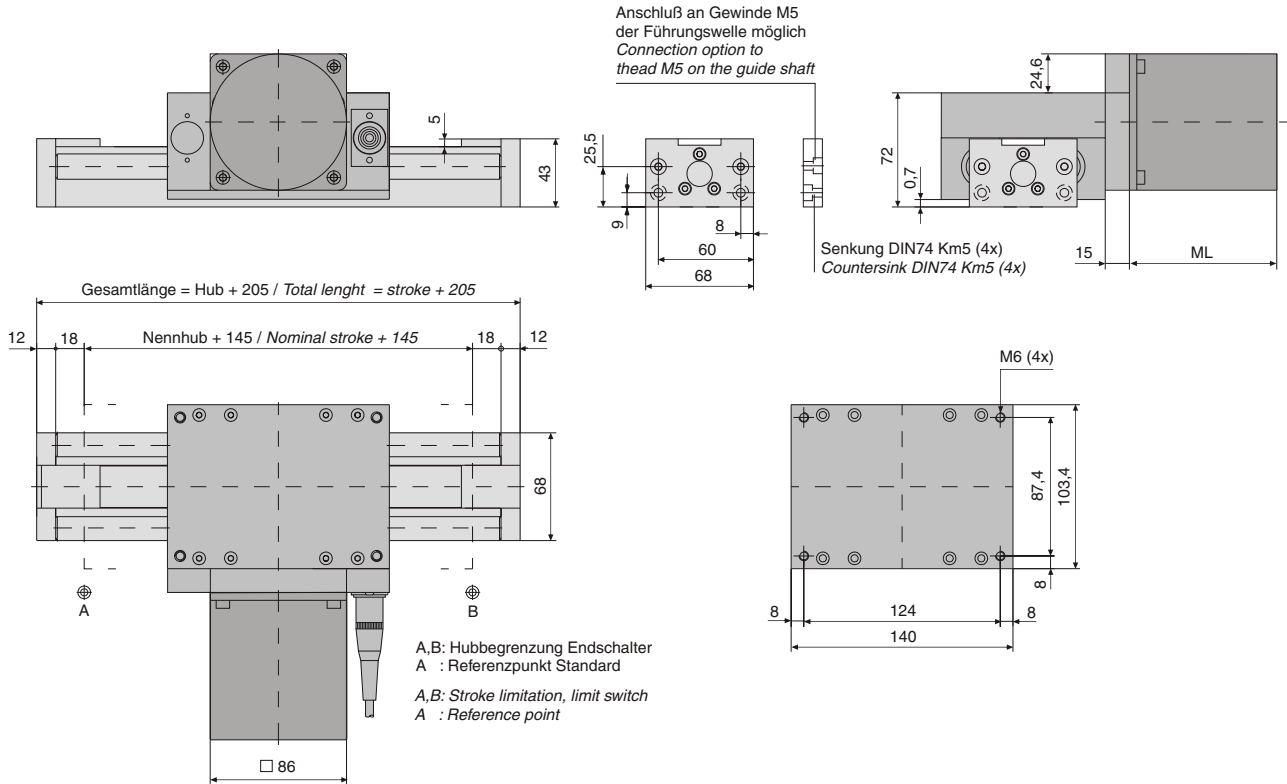

## Motoranbauvariante 2 / Motor attachment variant 2

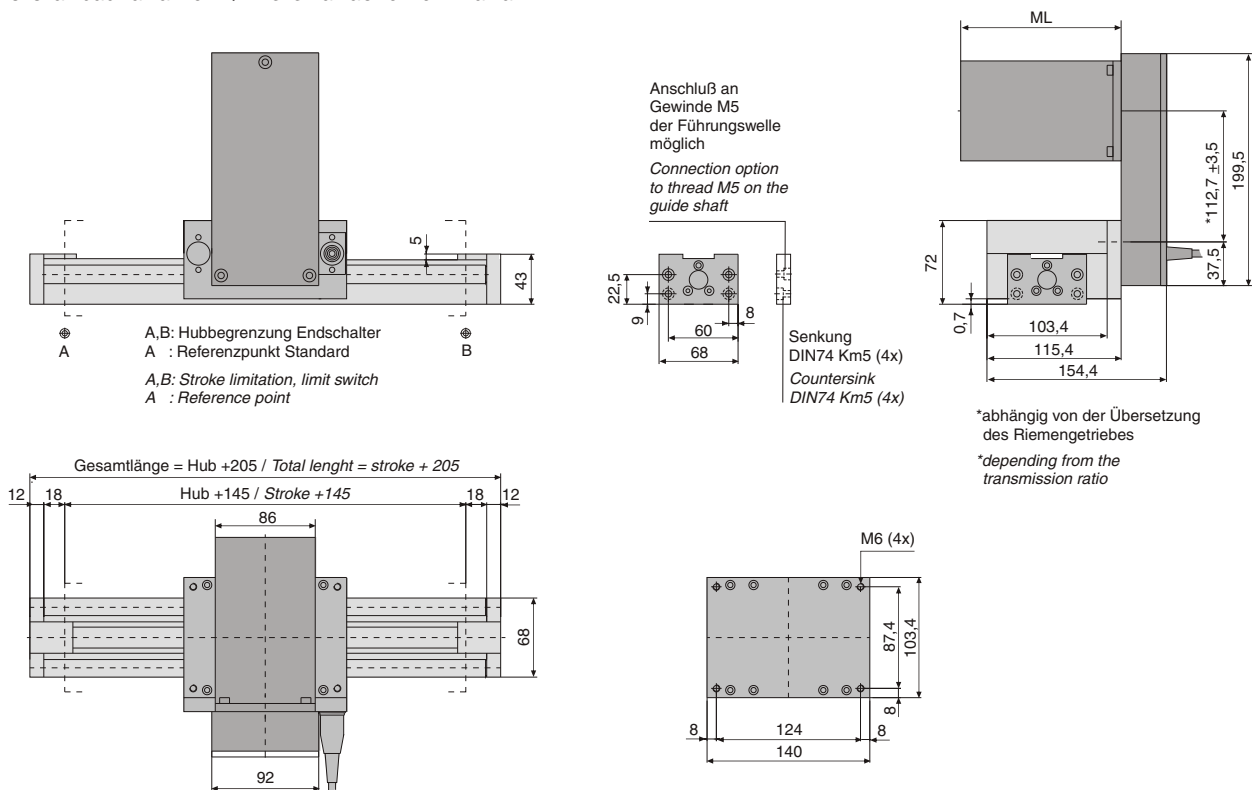

# Modul 68 / 68 D

## Motoranbauvariante 3 / Motor attachment variant 3

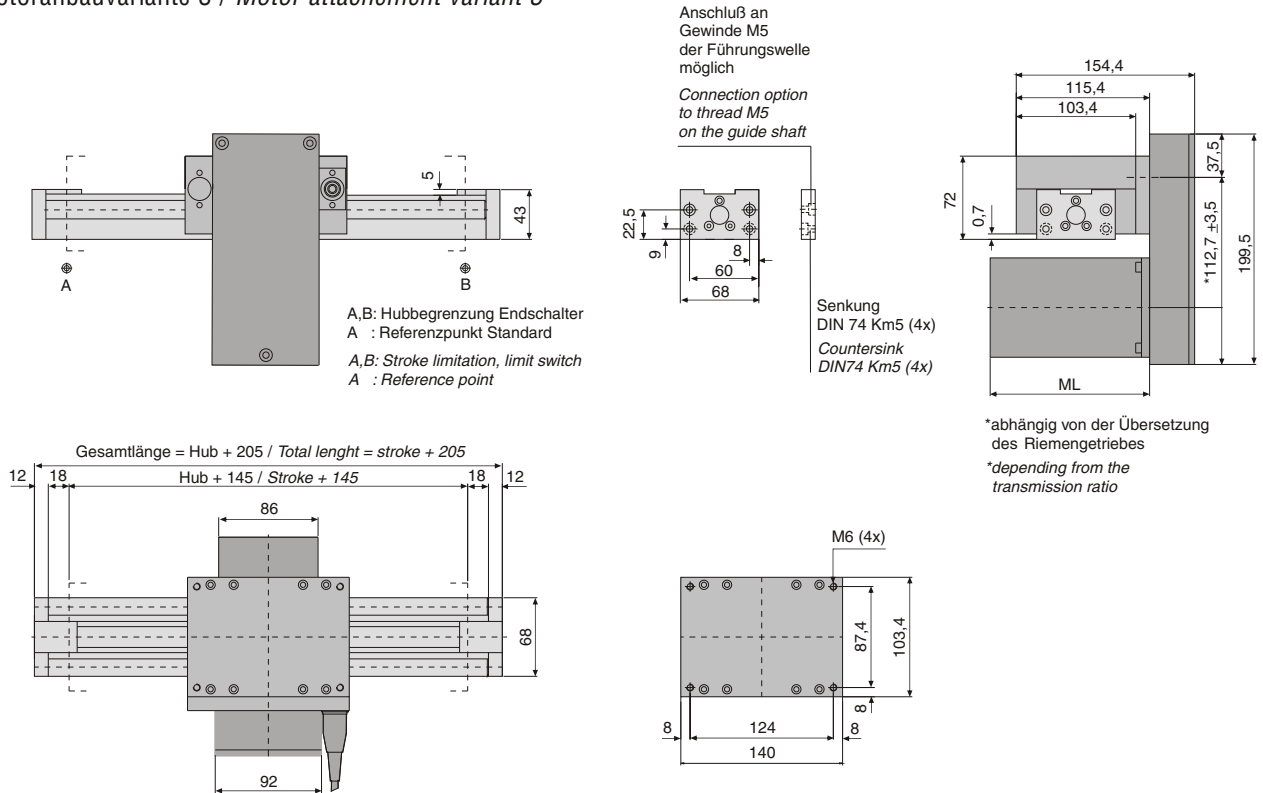

## Modul 68 D / Module 68 D

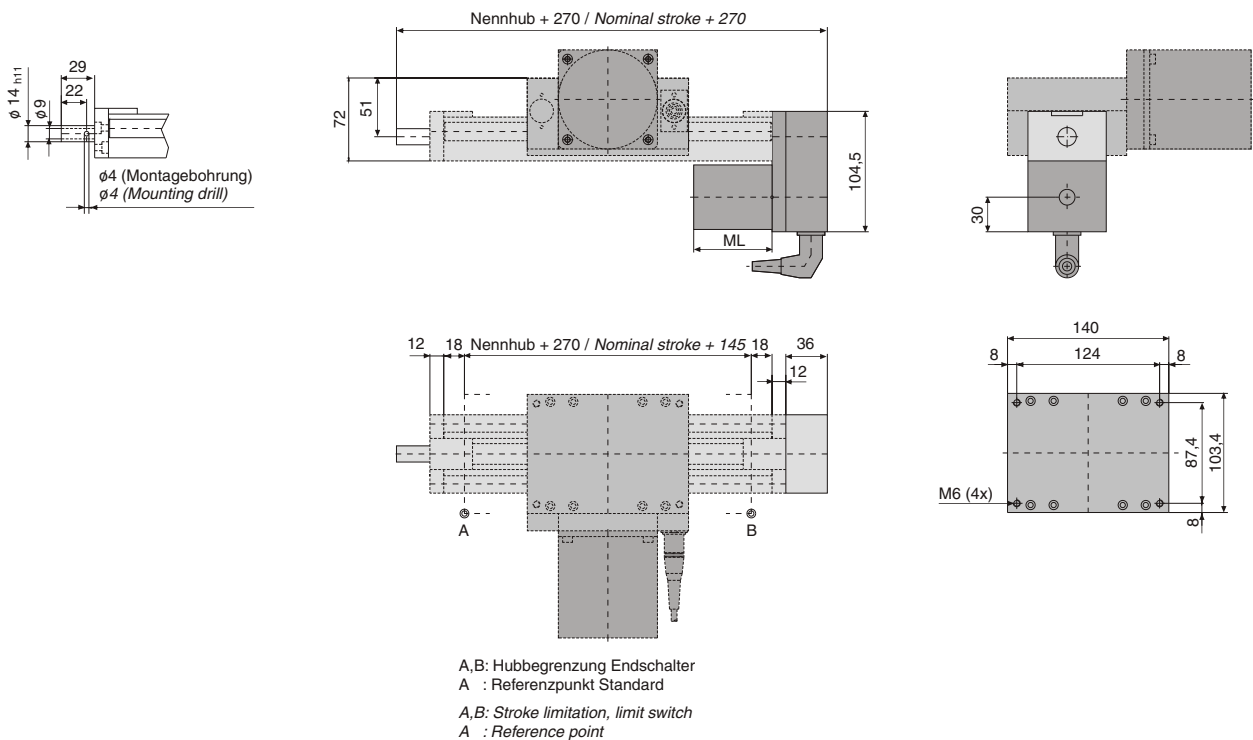

# Modul 90/15

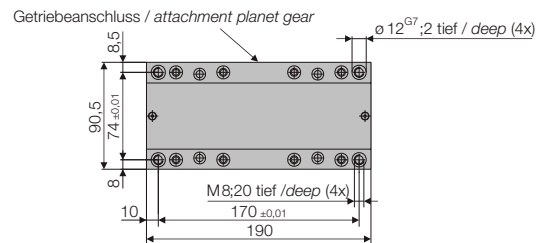
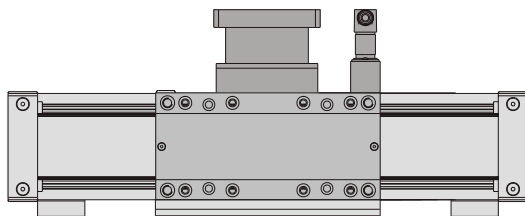
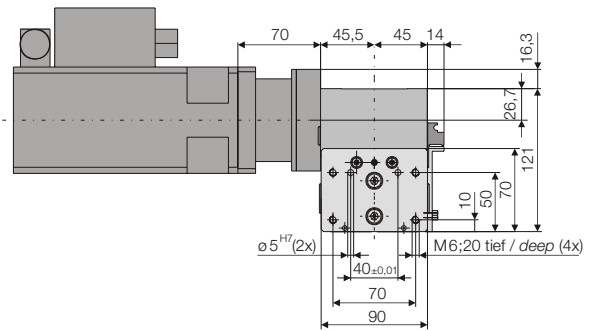
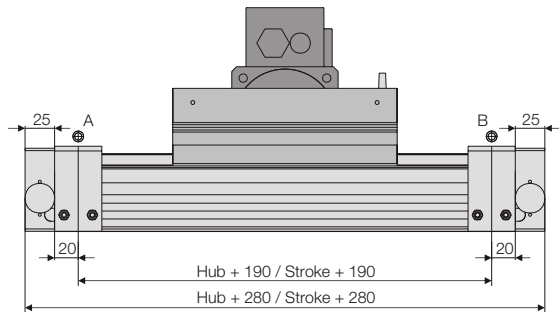

Schlittenmaße / carriage dimensions

A; B: Hubbegrenzung Endschalter  
 A : Referenzpunkt standard  
 A; B: Travel limitation, limit switch  
 A : Reference point standard

## Mit integrierter Drehachse / With integrated rotary axis

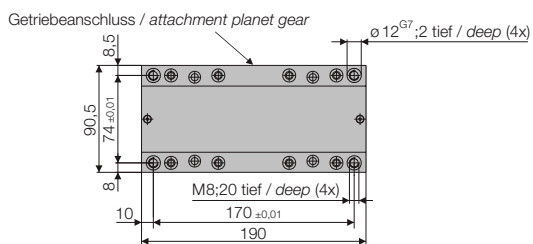
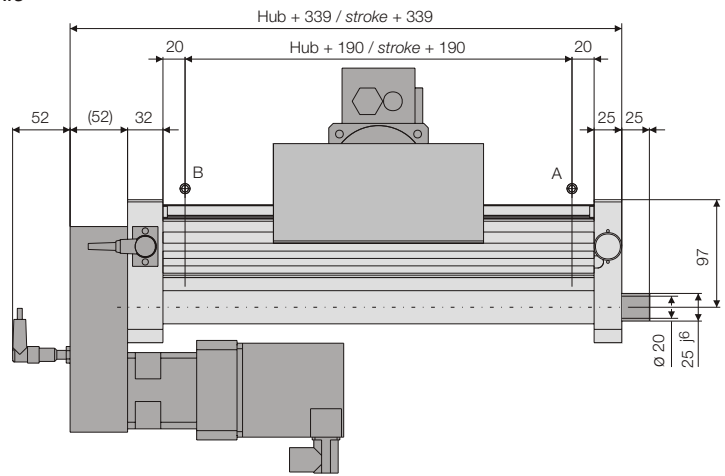
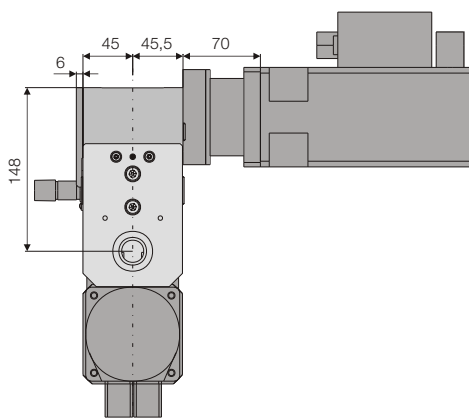

Schlittenmaße / carriage dimensions

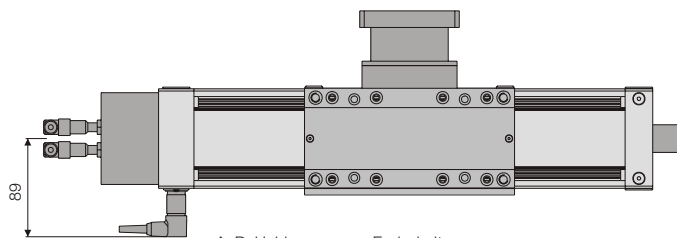

A; B: Hubbegrenzung Endschalter  
 A : Referenzpunkt standard  
 A; B: Travel limitation, limit switch  
 A : Reference point standard

# Modul 90/15 Teleskop

**Die Lineareinheit Modul 90/15 Teleskop bietet neben allen Vorzügen der Lineareinheit Modul 90/15 folgende Merkmale:**

- Großer Hub bei kompakten Abmessungen durch überlagerte Bewegung
- Extrem hohe Verfahrgeschwindigkeit bis 6 m/s am Auslegerarm

**Sie ist für folgende Einsatzgebiete besonders geeignet:**

- Be- und Entladen von Bearbeitungsmaschinen (z.B. Drehautomaten, Schleifmaschinen, etc.)
- Teileentnahme aus Spritzgussmaschinen mit Palettierung
- Abstapeleinrichtungen

**The linear unit Modul 80/15 Telescope offers, in addition to all advantages of the linear unit Modul 90/15, following features:**

- High stroke at compact dimensions by motion addition
- Extremely high speed up to 6 m/s at the extension arm

**It is particularly convenient for following applications:**

- Loading- and unloading of processing machines e. g. automatic lathes, grinding machines
- Picking up cast parts from injection molding machines with following palletising
- Destacking devices



■ Portalaufbau mit Modul 90/15 Teleskop  
Gantry system with Modul 90/15 Telescope



Auslegerarm / Extension arm

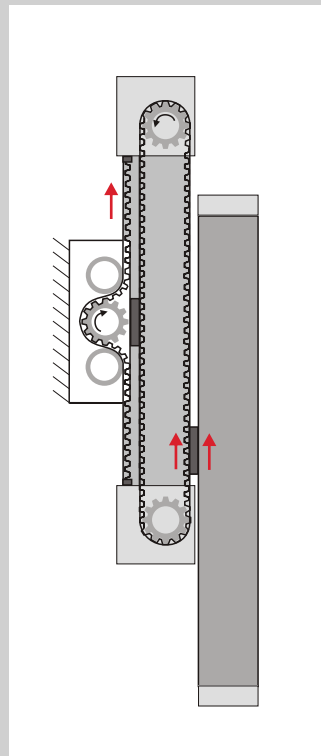

<b>Technische Daten</b> <i>Technical data</i>	
Hub <i>Stroke</i>	max. 1400 mm
Gewicht <i>Weight</i>	12,4 kg
Gewichtszunahme pro 120 mm Hub <i>Weight increase per 120 mm stroke</i>	1 kg
max. Geschwindigkeit am Ausleger <i>max. speed at the extension arm</i>	6 m/s
Wiederholgenauigkeit <i>Repeatability accuracy</i>	+/- 0,05 mm
Zahnriemen <i>Toothed belt</i>	50 ATL 5
Vorschubskonstante <i>Feed rate constant</i>	280 mm
Standardgetriebeuntersetzungen <i>Ratio</i>	5:1 / 8:1 / 16:1
max. Last im Vertikalbetrieb <i>max. Load in vertical movement</i>	5 kg